



**Test Report No. 608331-01-1A-2-3**

**Test Report Date: April 2019**

## **MASH TL-4 EVALUATION OF 2019 MASH 2-TUBE BRIDGE RAIL**

by

William F. Williams, P.E.  
Associate Research Engineer

Wanda L. Menges  
Research Specialist

and

Bill L. Griffith  
Research Specialist



**Contract No.: 1602767**

**Test No.: 608331-01-1A / 2 / 3**

**Test Date: 2018-12-10 / 12-12 / 12-14**

Sponsored by

**State of Alaska Department of Transportation and Public  
Facilities and North Dakota Department of Transportation**

### **TEXAS A&M TRANSPORTATION INSTITUTE PROVING GROUND**

Mailing Address:  
Roadside Safety & Physical Security  
Texas A&M University System  
3135 TAMU  
College Station, TX 77843-3135

Located at:  
Texas A&M University System RELLIS Campus  
Building 7091  
3100 State Highway 47  
Bryan, TX 77807



## DISCLAIMER

The contents of this report reflect the views of the authors, who are solely responsible for the facts and accuracy of the data, and the opinions, findings, and conclusions presented herein. The contents do not necessarily reflect the official views or policies of the State of Alaska Department of Transportation and Public Facilities, North Dakota Department of Transportation, The Texas A&M University System, or Texas A&M Transportation Institute. This report does not constitute a standard, specification, or regulation. In addition, the above listed agencies/companies assume no liability for its contents or use thereof. The names of specific products or manufacturers listed herein do not imply endorsement of those products or manufacturers.

The results reported herein apply only to the article being tested. The full-scale crash tests were performed according to TTI Proving Ground quality procedures and according to the *MASH* guidelines and standards.

The Proving Ground Laboratory within the Texas A&M Transportation Institute's Roadside Safety and Physical Security Division ("TTI Lab" or "TTI LAB") strives for accuracy and completeness in its crash test reports. On rare occasions, unintentional or inadvertent clerical errors, technical errors, omissions, oversights, or misunderstandings (collectively referred to as "errors") may occur and may not be identified for corrective action prior to the final report being published and issued. If, and when, the TTI Lab discovers an error in a published and issued final report, the TTI Lab shall promptly disclose such error to State of Alaska Department of Transportation and Public Facilities, and both parties shall endeavor in good faith to resolve this situation. The TTI Lab will be responsible for correcting the error that occurred in the report, which may be in form of errata, amendment, replacement sections, or up to and including full reissuance of the report. The cost of correcting an error in the report shall be borne by TTI Lab. Any such errors or inadvertent delays that occur in connection with the performance of the related testing contract shall not constitute a breach of the testing contract.

**THE TTI LAB SHALL NOT BE LIABLE FOR ANY INDIRECT, CONSEQUENTIAL, PUNITIVE, OR OTHER DAMAGES SUFFERED BY STATE OF ALASKA DEPARTMENT OF TRANSPORTATION AND PUBLIC FACILITIES, NORTH DAKOTA DEPARTMENT OF TRANSPORTATION, OR ANY OTHER PERSON OR ENTITY, WHETHER SUCH LIABILITY IS BASED, OR CLAIMED TO BE BASED, UPON ANY NEGLIGENT ACT, OMISSION, ERROR, CORRECTION OF ERROR, DELAY, OR BREACH OF AN OBLIGATION BY THE TTI LAB.**

1. Report No.		2. Government Accession No.		3. Recipient's Catalog No.	
4. Title and Subtitle <b>MASH TL-4 EVALUATION OF 2019 MASH 2-TUBE BRIDGE RAIL</b>				5. Report Date <b>April 2019</b>	
				6. Performing Organization Code	
7. Author(s) <b>William F. Williams, Wanda L. Menges, and Bill L. Griffith</b>				8. Performing Organization Report No. <b>Test Report No. 608331-01-1A-2-3</b>	
9. Performing Organization Name and Address <b>Texas A&amp;M Transportation Institute Proving Ground 3135 TAMU College Station, Texas 77843-3135</b>				10. Work Unit No. (TRAIS)	
				11. Contract or Grant No. <b>1602767</b>	
12. Sponsoring Agency Name and Address <b>State of Alaska Department of Transportation and Public Facilities Bridge Section 3132 Channel Drive – Room 100 Juneau, AK 99811-2500</b>				13. Type of Report and Period Covered <b>Technical Report: February 2016 – March 2019</b>	
				14. Sponsoring Agency Code	
15. Supplementary Notes <b>Project Title: MASH Testing – Bridge Rail and Thrie-Beam Transition Name of Contacting Representative: Elmer E. Marx – Alaska DOT&amp;PF</b>					
16. Abstract  <p>The purpose of the tests reported herein was to assess the performance of a new, taller Alaska Multi-State 2-Tube Bridge Rail (re-designated as 2019 MASH 2-Tube Bridge Rail) according to the safety-performance evaluation guidelines included in the American Association of State Highway and Transportation Officials (AASHTO), <i>Manual for Assessing Safety Hardware (MASH)</i>, Second Edition 2016. The crash tests performed were in accordance with <i>MASH</i> Test Level 4 (TL-4), which involves three tests on the 2019 MASH 2-Tube Bridge Rail.</p> <p>This report provides details of the 2019 MASH 2-Tube Bridge Rail, detailed documentation of the crash tests and results, and an assessment of the performance of the 2019 MASH 2-Tube Bridge Rail for <i>MASH</i> TL-4 evaluation criteria.</p> <p>The 2019 MASH 2-Tube Bridge Rail performed acceptably for <i>MASH</i> TL-4 longitudinal barriers.</p>					
17. Key Words <b>Bridge rail, longitudinal barrier, crash testing, MASH, roadside safety.</b>			18. Distribution Statement <b>Copyrighted. Not to be copied or reprinted without consent from the State of Alaska Department of Transportation and Public Facilities and North Dakota Department of Transportation.</b>		
19. Security Classif.(of this report) <b>Unclassified</b>		20. Security Classif.(of this page) <b>Unclassified</b>		21. No. of Pages <b>128</b>	22. Price

## SI\* (MODERN METRIC) CONVERSION FACTORS

### APPROXIMATE CONVERSIONS TO SI UNITS

Symbol	When You Know	Multiply By	To Find	Symbol
<b>LENGTH</b>				
in	inches	25.4	millimeters	mm
ft	feet	0.305	meters	m
yd	yards	0.914	meters	m
mi	miles	1.61	kilometers	km
<b>AREA</b>				
in <sup>2</sup>	square inches	645.2	square millimeters	mm <sup>2</sup>
ft <sup>2</sup>	square feet	0.093	square meters	m <sup>2</sup>
yd <sup>2</sup>	square yards	0.836	square meters	m <sup>2</sup>
ac	acres	0.405	hectares	ha
mi <sup>2</sup>	square miles	2.59	square kilometers	km <sup>2</sup>
<b>VOLUME</b>				
fl oz	fluid ounces	29.57	milliliters	mL
gal	gallons	3.785	liters	L
ft <sup>3</sup>	cubic feet	0.028	cubic meters	m <sup>3</sup>
yd <sup>3</sup>	cubic yards	0.765	cubic meters	m <sup>3</sup>
NOTE: volumes greater than 1000L shall be shown in m <sup>3</sup>				
<b>MASS</b>				
oz	ounces	28.35	grams	g
lb	pounds	0.454	kilograms	kg
T	short tons (2000 lb)	0.907	megagrams (or metric ton <sup>†</sup> )	Mg (or "t")
<b>TEMPERATURE (exact degrees)</b>				
°F	Fahrenheit	5(F-32)/9 or (F-32)/1.8	Celsius	°C
<b>FORCE and PRESSURE or STRESS</b>				
lbf	poundforce	4.45	newtons	N
lbf/in <sup>2</sup>	poundforce per square inch	6.89	kilopascals	kPa
<b>APPROXIMATE CONVERSIONS FROM SI UNITS</b>				
Symbol	When You Know	Multiply By	To Find	Symbol
<b>LENGTH</b>				
mm	millimeters	0.039	inches	in
m	meters	3.28	feet	ft
m	meters	1.09	yards	yd
km	kilometers	0.621	miles	mi
<b>AREA</b>				
mm <sup>2</sup>	square millimeters	0.0016	square inches	in <sup>2</sup>
m <sup>2</sup>	square meters	10.764	square feet	ft <sup>2</sup>
m <sup>2</sup>	square meters	1.195	square yards	yd <sup>2</sup>
ha	hectares	2.47	acres	ac
km <sup>2</sup>	Square kilometers	0.386	square miles	mi <sup>2</sup>
<b>VOLUME</b>				
mL	milliliters	0.034	fluid ounces	oz
L	liters	0.264	gallons	gal
m <sup>3</sup>	cubic meters	35.314	cubic feet	ft <sup>3</sup>
m <sup>3</sup>	cubic meters	1.307	cubic yards	yd <sup>3</sup>
<b>MASS</b>				
g	grams	0.035	ounces	oz
kg	kilograms	2.202	pounds	lb
Mg (or "t")	megagrams (or "metric ton")	1.103	short tons (2000lb)	T
<b>TEMPERATURE (exact degrees)</b>				
°C	Celsius	1.8C+32	Fahrenheit	°F
<b>FORCE and PRESSURE or STRESS</b>				
N	newtons	0.225	poundforce	lbf
kPa	kilopascals	0.145	poundforce per square inch	lb/in <sup>2</sup>

\*SI is the symbol for the International System of Units



## REPORT AUTHORIZATION

---

### REPORT REVIEWED BY:

DocuSigned by:

*Glenn Schroeder*

E092F9095047407...

Glenn Schroeder, Research Specialist  
Drafting & Reporting

DocuSigned by:

*Ken Reeves*

00D656995599400...

Ken Reeves, Research Specialist  
Electronics Instrumentation

DocuSigned by:

*Gary Gerke*

F0A2101E9F06487...

Gary Gerke, Research Specialist  
Construction

DocuSigned by:

*Richard Badillo*

DF31DA604E124F9...

Richard Badillo, Research Specialist  
Photographic Instrumentation

DocuSigned by:

*Scott Dobrovolny*

1C819665767644C...

Scott Dobrovolny, Research Specialist  
Mechanical Instrumentation

DocuSigned by:

*Wanda L. Menges*

092173022AF24FE...

Wanda L. Menges, Research Specialist  
Reporting & Deputy QM

DocuSigned by:

*Darrell L. Kuhn*

D4CC23E85D5B4E7...

Darrell L. Kuhn, P.E., Research Specialist  
Quality Manager

DocuSigned by:

*Matthew Robinson*

E7A228FA38FD417...

Matthew N. Robinson, Research Specialist  
Test Facility Manager & Technical Manager

DocuSigned by:

*William Williams*

2E84C4D2E3784AE...

William F. Williams, P.E.  
Associate Research Engineer



# TABLE OF CONTENTS

	Page
<b>Disclaimer .....</b>	<b>ii</b>
<b>List of Figures.....</b>	<b>ix</b>
<b>List of Tables .....</b>	<b>xi</b>
<b>Chapter 1. Introduction.....</b>	<b>1</b>
1.1 Problem Statement .....	1
1.2 Background.....	1
1.3 Objective.....	1
<b>Chapter 2. System Details.....</b>	<b>3</b>
2.1. Test Article and Installation Details .....	3
2.2. Material Specifications .....	3
<b>Chapter 3. Test Requirements and Evaluation Criteria .....</b>	<b>7</b>
3.1. Crash Test Performed / Matrix .....	7
3.2. Evaluation Criteria.....	7
<b>Chapter 4. Test Conditions.....</b>	<b>9</b>
4.1. Test Facility .....	9
4.2 Vehicle Tow and Guidance System.....	9
4.3 Data Acquisition Systems .....	9
4.3.1 Vehicle Instrumentation and Data Processing .....	9
4.3.2 Anthropomorphic Dummy Instrumentation .....	10
4.3.3 Photographic Instrumentation Data Processing .....	11
<b>Chapter 5. MASH Test 4-12 (Crash Test No. 608331-01-1A) .....</b>	<b>13</b>
5.1 Test Designation and Actual Impact Conditions .....	13
5.2 Weather Conditions .....	13
5.3 Test Vehicle .....	13
5.4 Test Description .....	14
5.5 Damage to Test Installation .....	14
5.6 Vehicle Damage.....	16
5.7 Occupant Risk Factors .....	17
<b>Chapter 6. MASH Test 4-11 (Crash Test No. 608331-01-2) .....</b>	<b>21</b>
6.1 Test Designation and Actual Impact Conditions .....	21
6.2 Weather Conditions .....	21
6.3 Test Vehicle .....	21
6.4 Test Description .....	22
6.5 Damage to Test Installation .....	23
6.6 Vehicle Damage.....	24
6.7 Occupant Risk Factors .....	25
<b>Chapter 7. MASH Test 4-10 (Crash Test No. 608331-01-3) .....</b>	<b>29</b>
7.1 Test Designation and Actual Impact Conditions .....	29
7.2 Weather Conditions .....	29
7.3 Test Vehicle .....	29
7.4 Test Description .....	30
7.5 Damage to Test Installation .....	30

## TABLE OF CONTENTS (CONTINUED)

	<b>Page</b>
7.6 Vehicle Damage.....	32
7.7 Occupant Risk Factors .....	33
<b>Chapter 8. Summary and Conclusions .....</b>	<b>37</b>
8.1 Assessment of Test Results.....	37
8.2 Conclusions.....	37
<b>References.....</b>	<b>43</b>
<b>Appendix A. Details of the 2019 MASH 2-Tube Bridge Rail.....</b>	<b>45</b>
<b>Appendix B. Supporting Certification Documents.....</b>	<b>53</b>
<b>Appendix C. MASH Test 4-12 (Crash Test No. 608331-01-1A).....</b>	<b>77</b>
C1 Vehicle Properties and Information .....	77
C2 Sequential Photographs.....	79
C3 Vehicle Angular Displacements .....	82
C4 Vehicle Accelerations .....	83
<b>Appendix D. MASH Test 4-11 (Crash Test No. 608331-01-2).....</b>	<b>89</b>
D1 Vehicle Properties and Information .....	89
D2 Sequential Photographs.....	93
D3 Vehicle Angular Displacements .....	96
D4 Vehicle Accelerations .....	97
<b>Appendix E. MASH Test 4-10 (Crash Test No. 608331-01-3).....</b>	<b>103</b>
E1 Vehicle Properties and Information .....	103
E2 Sequential Photographs.....	106
E3 Vehicle Angular Displacements .....	109
E4 Vehicle Accelerations .....	110

## LIST OF FIGURES

	<b>Page</b>
Figure 2.1. Details of the 2019 MASH 2-Tube Bridge Rail. ....	4
Figure 2.2. 2019 MASH 2-Tube Bridge Rail prior to Testing. ....	5
Figure 5.1. 2019 MASH 2-Tube Bridge Rail/Test Vehicle Geometrics for Test No. 608331-01-1A. ....	13
Figure 5.2. Test Vehicle before Test No. 608331-01-1A. ....	14
Figure 5.3. Overall Damage to Alaska Bridge Rail after Test No. 608331-01-1A. ....	15
Figure 5.4. Impact Area after Test No. 608331-01-1A. ....	16
Figure 5.5. Test Vehicle after Test No. 608331-01-1A. ....	17
Figure 5.6. Interior of Test Vehicle after Test No. 608331-01-1A. ....	17
Figure 5.7. Summary of Results for <i>MASH</i> Test 4-12 on 2019 MASH 2-Tube Bridge Rail. ....	19
Figure 6.1. 2019 MASH 2-Tube Bridge Rail/Test Vehicle Geometrics for Test No. 608331-01-2. ....	21
Figure 6.2. Test Vehicle before Test No. 608331-01-2. ....	22
Figure 6.3. 2019 MASH 2-Tube Bridge Rail after Test No. 608331-01-2. ....	23
Figure 6.4. Damage at Post 9 after Test No. 608331-01-2. ....	24
Figure 6.5. Test Vehicle after Test No. 608331-01-2. ....	25
Figure 6.6. Interior of Test Vehicle for Test No. 608331-01-2. ....	25
Figure 6.7. Summary of Results for <i>MASH</i> Test 4-11 on 2019 MASH 2-Tube Bridge Rail. ....	27
Figure 7.1. 2019 MASH 2-Tube Bridge Rail/Test Vehicle Geometrics for Test No. 608331-01-3. ....	29
Figure 7.2. Test Vehicle before Test No. 608331-01-3. ....	30
Figure 7.3. 2019 MASH 2-Tube Bridge Rail after Test No. 608331-01-3. ....	31
Figure 7.4. Damage at Post 13 after Test No. 608331-01-3. ....	32
Figure 7.5. Test Vehicle after Test No. 608331-01-3. ....	33
Figure 7.6. Interior of Test Vehicle for Test No. 608331-01-3. ....	33
Figure 7.7. Summary of Results for <i>MASH</i> Test 4-10 on 2019 MASH 2-Tube Bridge Rail. ....	35
Figure C.1. Sequential Photographs for Test No. 608331-01-1A (Overhead and Frontal Views). ....	79
Figure C.2. Sequential Photographs for Test No. 608331-01-1A (Rear View). ....	81
Figure C.3. Vehicle Angular Displacements for Test No. 608331-01-1A. ....	82
Figure C.4. Vehicle Longitudinal Accelerometer Trace for Test No. 608331-01-1A (Accelerometer Located at Center of Gravity). ....	83
Figure C.5. Vehicle Lateral Accelerometer Trace for Test No. 608331-01-1A (Accelerometer Located at Center of Gravity). ....	84
Figure C.6. Vehicle Vertical Accelerometer Trace for Test No. 608331-01-1A (Accelerometer Located at Center of Gravity). ....	85
Figure C.7. Vehicle Longitudinal Accelerometer Trace for Test No. 608331-01-1A (Accelerometer Located Rear of Center of Gravity). ....	86
Figure C.8. Vehicle Lateral Accelerometer Trace for Test No. 608331-01-1A (Accelerometer Located Rear of Center of Gravity). ....	87

## LIST OF FIGURES (CONTINUED)

		<b>Page</b>
Figure C.9.	Vehicle Vertical Accelerometer Trace for Test No. 608331-01-1A (Accelerometer Located Rear of Center of Gravity). .....	88
Figure D.1.	Sequential Photographs for Test No. 608331-01-2 (Overhead and Frontal Views). .....	93
Figure D.2.	Sequential Photographs for Test No. 608331-01-2 (Rear View). .....	95
Figure D.3.	Vehicle Angular Displacements for Test No. 608331-01-2. ....	96
Figure D.4.	Vehicle Longitudinal Accelerometer Trace for Test No. 608331-01-2 (Accelerometer Located at Center of Gravity). .....	97
Figure D.5.	Vehicle Lateral Accelerometer Trace for Test No. 608331-01-2 (Accelerometer Located at Center of Gravity). .....	98
Figure D.6.	Vehicle Vertical Accelerometer Trace for Test No. 608331-01-2 (Accelerometer Located at Center of Gravity). .....	99
Figure D.7.	Vehicle Longitudinal Accelerometer Trace for Test No. 608331-01-2 (Accelerometer Located Rear of Center of Gravity). .....	100
Figure D.8.	Vehicle Lateral Accelerometer Trace for Test No. 608331-01-2 (Accelerometer Located Rear of Center of Gravity). .....	101
Figure D.9.	Vehicle Vertical Accelerometer Trace for Test No. 608331-01-2 (Accelerometer Located Rear of Center of Gravity). .....	102
Figure E.1.	Sequential Photographs for Test No. 608331-01-3 (Overhead and Frontal Views). .....	106
Figure E.2.	Sequential Photographs for Test No. 608331-01-3 (Rear View). .....	108
Figure E.3.	Vehicle Angular Displacements for Test No. 608331-01-3. ....	109
Figure E.4.	Vehicle Longitudinal Accelerometer Trace for Test No. 608331-01-3 (Accelerometer Located at Center of Gravity). .....	110
Figure E.5.	Vehicle Lateral Accelerometer Trace for Test No. 608331-01-3 (Accelerometer Located at Center of Gravity). .....	111
Figure E.6.	Vehicle Vertical Accelerometer Trace for Test No. 608331-01-3 (Accelerometer Located at Center of Gravity). .....	112
Figure E.7.	Vehicle Longitudinal Accelerometer Trace for Test No. 608331-01-3 (Accelerometer Located Rear of Center of Gravity). .....	113
Figure E.8.	Vehicle Lateral Accelerometer Trace for Test No. 608331-01-3 (Accelerometer Located Rear of Center of Gravity). .....	114
Figure E.9.	Vehicle Vertical Accelerometer Trace for Test No. 608331-01-3 (Accelerometer Located Rear of Center of Gravity). .....	115

## LIST OF TABLES

		<b>Page</b>
Table 3.1.	Test Conditions and Evaluation Criteria Specified for <i>MASH</i> TL-3 Longitudinal Barriers. ....	7
Table 3.2.	Evaluation Criteria Required for <i>MASH</i> TL-4 for Longitudinal Barriers.....	8
Table 5.1.	Events during Test No. 608331-01-1A. ....	14
Table 5.2.	Occupant Risk Factors for Test No. 608331-01-1A. ....	18
Table 6.1.	Events during Test No. 608331-01-2.....	22
Table 6.2.	Occupant Risk Factors for Test No. 608331-01-2. ....	26
Table 7.1.	Events during Test No. 608331-01-3.....	30
Table 7.2.	Occupant Risk Factors for Test No. 608331-01-3. ....	34
Table 8.1.	Performance Evaluation Summary for <i>MASH</i> Test 4-12 on 2019 <i>MASH</i> 2- Tube Bridge Rail.....	38
Table 8.2.	Performance Evaluation Summary for <i>MASH</i> Test 4-11 on 2019 <i>MASH</i> 2- Tube Bridge Rail.....	39
Table 8.3.	Performance Evaluation Summary for <i>MASH</i> Test 4-10 on 2019 <i>MASH</i> 2- Tube Bridge Rail.....	40
Table 8.4.	Assessment Summary for <i>MASH</i> TL-4 Tests on 2019 <i>MASH</i> 2-Tube Bridge Rail. ....	41
Table C.1.	Vehicle Properties for Test No. 608331-01-1A.....	77
Table D.1.	Vehicle Properties for Test No. 608331-01-2.....	89
Table D.2.	Measurements of Vehicle Vertical CG for Test No. 608331-01-2. ....	90
Table D.3.	Exterior Crush Measurements for Test No. 608331-01-2. ....	91
Table D.4.	Occupant Compartment Measurements for Test No. 608331-01-2.....	92
Table E.1.	Vehicle Properties for Test No. 608331-01-3.....	103
Table E.2.	Exterior Crush Measurements for Test No. 608331-01-3. ....	104
Table E.3.	Occupant Compartment Measurements for Test No. 608331-01-3.....	105

*This page intentionally left blank.*



# Chapter 1. INTRODUCTION

## 1.1 PROBLEM STATEMENT

The Federal Highway Administration/American Association of State Highway and Transportation Officials (AASHTO) joint implementation date for all bridge railing designs to meet the requirements of AASHTO *Manual for Assessing Safety Hardware (MASH)* is December 31, 2019 (1,2). There is a need to re-evaluate commonly used bridge rails with respect to the *MASH* requirements. The purpose of this project is to evaluate the Alaska 2-Tube Bridge Rail and the Alaska Thrie-Beam Transition with respect to *MASH* requirements. This bridge rail has been successfully crash tested to National Cooperative Highway Research Program (NCHRP) *Report 350* Test Level 4 (TL-4) specifications (3-6). A thrie-beam transition and a W-beam transition were successfully tested to *NCHRP Report 350* specifications for TL-4 and TL-3, respectively (7-10). Alaska DOT and several other northwestern states currently use the Alaska 2-Tube Bridge Rail and the two transitions that are used in conjunction with the Alaska 2-Tube Bridge Rail design. Some modifications and improvements (e.g., taller) were made to the existing Alaska 2-Tube Bridge Rail to enable this design to meet the requirements for *MASH* TL-4. The purpose of this project was to make design improvements as necessary for the bridge rail and thrie-beam transition and evaluate the performance of these designs using full-scale crash testing with respect to *MASH* guidelines for Test Level 4.

## 1.2 BACKGROUND

In May 1998, Texas A&M Transportation Institute contracted with Alaska Department of Transportation to perform engineering analyses, design, and full-scale testing on the following:

- 1.) Alaska Multi-State (2-Tube) Bridge Rail.
- 2.) Alaska Multi-State Bridge Rail Thrie-Beam Transition.
- 3.) Alaska Multi-State W-Beam Transition.

Under that project (TTI Project No. 404311), TTI researchers performed engineering analyses, developed engineering details, and performed full-scale crash testing on the Alaska Multi-State (2-Tube) Bridge Rail. The bridge rail successfully met the performance requirements of *NCHRP Report 350* Test Level 4 (TL-4). As part of this current project, TTI researchers also performed analyses, design, and full-scale testing for a new Alaska Multi-State Bridge Rail Thrie-Beam Transition. This new thrie beam transition design will be tested with respect to *MASH* TL-3 and is planned for later.

## 1.3 OBJECTIVE

For this project, TTI researchers evaluated the strength and performance of a new, taller Alaska Multi-State 2-Tube Bridge Rail, herein after re-designated as the 2019 *MASH* 2-Tube Bridge Rail, with respect to *MASH*, Second Edition 2016, specifications. TTI researchers performed engineering analyses and developed engineering details for this design to meet the performance requirements of *MASH* TL-4. TTI Proving Ground performed full-scale crash testing on the final 2019 *MASH* 2-Tube Bridge Rail with respect to *MASH* TL-4.

The purpose of the tests reported herein was to assess the performance of the 2019 MASH 2-Tube Bridge Rail according to the safety-performance evaluation guidelines included in AASHTO *MASH*. The crash tests performed were in accordance with *MASH* TL-4, which involves three full-scale crash tests on the 2019 MASH 2-Tube Bridge Rail.

This report provides details of the 2019 MASH 2-Tube Bridge Rail, detailed documentation of the crash tests and results, and an assessment of the performance of the 2019 MASH 2-Tube Bridge Rail for *MASH* TL-4 evaluation criteria.

## **Chapter 2. SYSTEM DETAILS**

### **2.1. TEST ARTICLE AND INSTALLATION DETAILS**

The concrete portion of the 2019 MASH 2-Tube Bridge Rail test installation was 154 ft long, and consisted of a reinforced cantilevered deck and curb, with two 2-inch wide joints extending through both the curb and the deck. The curb was 10 inches tall, with a 4-inch thick lift of grout, yielding a 6-inch tall traffic side face. A 2-sack grout mix was used to simulate asphalt which is typically used on the bridge applications. The curb was 18 inches wide at the base, and 17 inches wide at the top, with the traffic side face sloping 1 inch toward the field side. Anchor bolts were cast in the deck and extended through the curb.

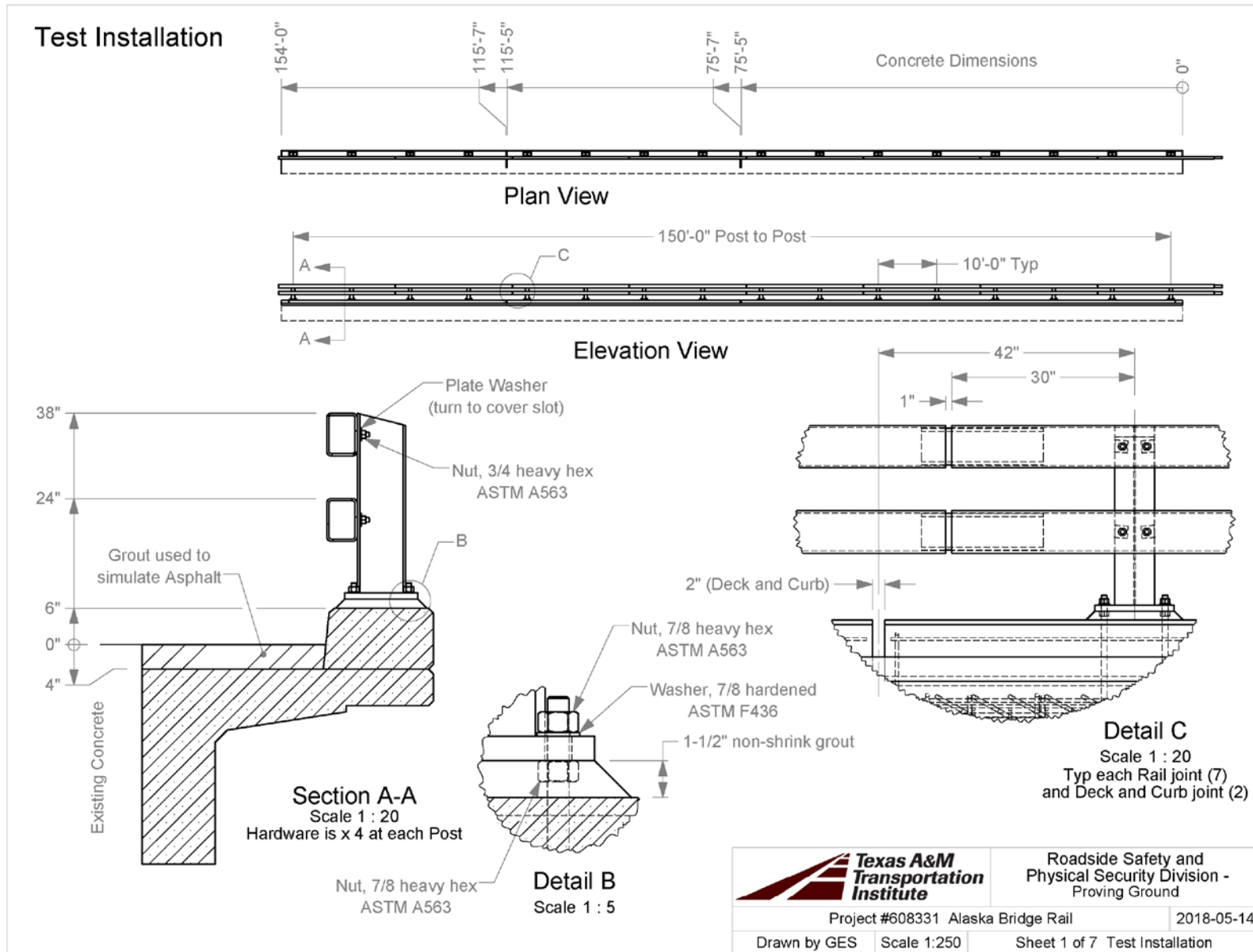
Sixteen fabricated steel posts were longitudinally spaced on 10 feet centers, beginning at 24 inches from each end of the concrete curb. Two steel rectangular HSS rail elements spanned the posts, and extended past them at each end of the installation. The top of the rails were located 24 inches and 38 inches above grade (i.e. the grout on the concrete deck).

Figure 2.1 presents overall information on the 2019 MASH 2-Tube Bridge Rail, and Figure 2.2 provides photographs of the installation. Appendix A provides further details of the 2019 MASH 2-Tube Bridge Rail.

### **2.2. MATERIAL SPECIFICATIONS**

The specified minimum unconfined compressive strength of the concrete for the curb was 4000 psi and for the deck was 5000 psi. On December 10, 2018, the average compressive strength of the concrete used in the curb was 5060 psi (at 42 days), and that in the deck was 5670 psi (at 44 days).

Appendix B provides material certification documents for the materials used to install/construct the 2019 MASH 2-Tube Bridge Rail.



T:\1-ProjectFiles\608331- Alaska - Williams\Drafting - 608331 1-3\608331 Drawing

Figure 2.1. Details of the 2019 MASH 2-Tube Bridge Rail.





**Figure 2.2. 2019 MASH 2-Tube Bridge Rail prior to Testing.**

*This page intentionally left blank.*

## Chapter 3. TEST REQUIREMENTS AND EVALUATION CRITERIA

### 3.1. CRASH TEST PERFORMED / MATRIX

According to *MASH*, three tests are recommended to evaluate longitudinal barriers to TL-4, details of which are shown in Table 3.1

**Table 3.1. Test Conditions and Evaluation Criteria Specified for *MASH* TL-4 Longitudinal Barriers.**

Test Article	Test Designation	Test Vehicle	Impact Conditions		Evaluation Criteria
			Speed	Angle	
Longitudinal Barrier	4-10	1100C	62 mi/h	25°	A, D, F, H, I
	4-11	2270P	62 mi/h	25°	A, D, F, H, I
	4-12	10000S	56 mi/h	15°	A, D, G

*MASH* Tests 4-10 and 4-11 evaluate a barrier's ability to successfully contain and redirect passenger vehicles and evaluate occupant risk. *MASH* Test 4-12 evaluates the structural adequacy of the bridge rail. All three tests were performed on the bridge rail.

The target critical impact point (CIP) for each test was determined in accordance with the guidance provided in *MASH Section 2.3.2* and *MASH Table 2-7*. For *MASH* Test 4-10, the target CIP was 3.6 ft upstream of the centerline of post 13. The target CIP for *MASH* Test 4-11 was 4.3 ft upstream of the centerline of post 9. For *MASH* 4-12, the target CIP was 5.0 ft upstream of the centerline of post 5.

The crash tests and data analysis procedures were in accordance with guidelines presented in *MASH*. Chapter 4 presents brief descriptions of these procedures.

### 3.2. EVALUATION CRITERIA

The appropriate safety evaluation criteria from *MASH Table 2-2* and *MASH Table 5-1* were used to evaluate the crash tests reported herein. The test conditions and evaluation criteria required for *MASH* TL-4 tests are listed in Table 3.1, and the substance of the evaluation criteria in Table 3.2. An evaluation of the crash test results is presented in detail under the section Assessment of Test Results.



**Table 3.2. Evaluation Criteria Required for MASH TL-4 for Longitudinal Barriers.**

<b>Evaluation Factors</b>	<b>Evaluation Criteria</b>	<b>Test Designation</b>
<b>Structural Adequacy</b>	A. <i>Test article should contain and redirect the vehicle or bring the vehicle to a controlled stop; the vehicle should not penetrate, underride, or override the installation although controlled lateral deflection of the test article is acceptable.</i>	4-10, 4-11, 4-12
<b>Occupant Risk</b>	D. <i>Detached elements, fragments, or other debris from the test article should not penetrate or show potential for penetrating the occupant compartment, or present undue hazard to other traffic, pedestrians, or personnel in a work zone.</i>  <i>Deformations of, or intrusions into, the occupant compartment should not exceed limits set forth in Section 5.2.2 and Appendix E of MASH.</i>	4-10, 4-11, 4-12
	F. <i>The vehicle should remain upright during and after collision. The maximum roll and pitch angles are not to exceed 75 degrees.</i>	4-10, 4-11
	G. <i>It is preferable, although not essential, that the vehicle remain upright during and after the collision.</i>	4-12
	H. <i>Occupant impact velocities (OIV) should satisfy the following limits: Preferred value of 30 ft/s, or maximum allowable value of 40 ft/s.</i>	4-10, 4-11
I. <i>The occupant ridedown accelerations should satisfy the following: Preferred value of 15.0 g, or maximum allowable value of 20.49 g.</i>	4-10, 4-11	



## **Chapter 4. TEST CONDITIONS**

### **4.1. TEST FACILITY**

The full-scale crash test reported herein were performed at Texas A&M Transportation Institute (TTI) Proving Ground, an International Standards Organization (ISO)/International Electrotechnical Commission (IEC) 17025-accredited laboratory with American Association for Laboratory Accreditation (A2LA) Mechanical Testing Certificate 2821.01. The full-scale crash tests were performed according to TTI Proving Ground quality procedures, and according to the *MASH* guidelines and standards.

The test facilities of the TTI Proving Ground are located on the Texas A&M University System RELLIS Campus, which consists of a 2000-acre complex of research and training facilities situated 10 miles northwest of the flagship campus of Texas A&M University. The site, formerly a United States Army Air Corps base, has large expanses of concrete runways and parking aprons well suited for experimental research and testing in the areas of vehicle performance and handling, vehicle-roadway interaction, durability and efficacy of highway pavements, and evaluation of roadside safety hardware and perimeter protective devices. The site selected for construction and testing of the 2019 MASH 2-Tube Bridge Rail was along the edge of an out-of-service apron. The apron consists of an unreinforced jointed-concrete pavement in 12.5-ft × 15-ft blocks nominally 6 inches deep. The aprons were built in 1942, and the joints have some displacement, but are otherwise flat and level.

### **4.2 VEHICLE TOW AND GUIDANCE SYSTEM**

Each test vehicle was towed into the test installation using a steel cable guidance and reverse tow system. A steel cable for guiding the test vehicle was tensioned along the path, anchored at each end, and threaded through an attachment to the front wheel of the test vehicle. An additional steel cable was connected to the test vehicle, passed around a pulley near the impact point, through a pulley on the tow vehicle, and then anchored to the ground such that the tow vehicle moved away from the test site. A 2:1 speed ratio between the test and tow vehicle existed with this system. Just prior to impact with the installation, the test vehicle was released and ran unrestrained. The vehicle remained freewheeling (i.e., no steering or braking inputs) until it cleared the immediate area of the test site (no sooner than 2 s after impact), after which the brakes were activated, if needed, to bring the test vehicle to a safe and controlled stop.

### **4.3 DATA ACQUISITION SYSTEMS**

#### **4.3.1 Vehicle Instrumentation and Data Processing**

Each test vehicle was instrumented with a self-contained, on-board data acquisition system. The signal conditioning and acquisition system is a 16-channel, Tiny Data Acquisition System (TDAS) Pro produced by Diversified Technical Systems, Inc. The accelerometers, which measure the x, y, and z axis of vehicle acceleration, are strain gauge type with linear millivolt output proportional to acceleration. Angular rate sensors, measuring vehicle roll, pitch, and yaw rates, are ultra-small, solid state units designed for crash test service. The TDAS Pro hardware

and software conform to the latest SAE J211, Instrumentation for Impact Test. Each of the 16 channels is capable of providing precision amplification, scaling, and filtering based on transducer specifications and calibrations. During the test, data are recorded from each channel at a rate of 10,000 values per second with a resolution of one part in 65,536. Once data are recorded, internal batteries back these up inside the unit should the primary battery cable be severed. Initial contact of the pressure switch on the vehicle bumper provides a time zero mark as well as initiates the recording process. After each test, the data are downloaded from the TDAS Pro unit into a laptop computer at the test site. The Test Risk Assessment Program (TRAP) software then processes the raw data to produce detailed reports of the test results.

Each of the TDAS Pro units is returned to the factory annually for complete recalibration and all instrumentation used in the vehicle conforms to all specifications outlined by SAE J211. All accelerometers are calibrated annually by means of an ENDEVCO® 2901, precision primary vibration standard. This standard and its support instruments are checked annually and receive a National Institute of Standards Technology (NIST) traceable calibration. The rate transducers used in the data acquisition system receive a calibration via a Genisco Rate-of-Turn table. The subsystems of each data channel are also evaluated annually, using instruments with current NIST traceability, and the results are factored into the accuracy of the total data channel, per SAE J211. Calibrations and evaluations are also made any time data are suspect. Acceleration data is measured with an expanded uncertainty of  $\pm 1.7$  percent at a confidence factor of 95 percent ( $k=2$ ).

TRAP uses the data from the TDAS Pro to compute occupant/compartment impact velocities, time of occupant/compartment impact after vehicle impact, and the highest 10-millisecond (ms) average ridedown acceleration. TRAP calculates change in vehicle velocity at the end of a given impulse period. In addition, maximum average accelerations over 50-ms intervals in each of the three directions are computed. For reporting purposes, the data from the vehicle-mounted accelerometers are filtered with SAE Class 180 low-pass filters, and acceleration versus time curves for the longitudinal, lateral, and vertical directions are plotted using TRAP.

TRAP uses the data from the yaw, pitch, and roll rate transducers to compute angular displacement in degrees at 0.0001-s intervals, then plots yaw, pitch, and roll versus time. These displacements are in reference to the vehicle-fixed coordinate system with the initial position and orientation of the vehicle-fixed coordinate systems being initial impact. Rate of rotation data is measured with an expanded uncertainty of  $\pm 0.7$  percent at a confidence factor of 95 percent ( $k=2$ ).

#### **4.3.2 Anthropomorphic Dummy Instrumentation**

An Alderson Research Laboratories Hybrid II, 50th percentile male anthropomorphic dummy, restrained with lap and shoulder belts, was placed in the front seat on the impact side of the 1100C vehicle. The dummy was not instrumented.

According to *MASH*, use of a dummy in the 2270P vehicle is optional. However, it is recommended a dummy be used when testing “any longitudinal barrier with a height greater than

or equal to 33 inches.” Use of the dummy in the 2270P vehicle is recommended for tall rails to evaluate the “potential for an occupant to extend out of the vehicle and come into direct contact with the test article.” Although this information is reported, it is not part of the impact performance evaluation. Since the rail height of the 2019 MASH 2-Tube Bridge Rail was 38 inches, a dummy was placed in the front seat of the 2270P vehicle on the impact side and restrained with lap and shoulder belts.

#### **4.3.3 Photographic Instrumentation Data Processing**

Photographic coverage of each test included three digital high-speed cameras:

- One overhead with a field of view perpendicular to the ground and directly over the impact point;
- One placed behind the installation at an angle; and
- A third placed to have a field of view parallel to and aligned with the installation at the downstream end.

A flashbulb on each impacting vehicle was activated by a pressure-sensitive tape switch to indicate the instant of contact with the 2019 MASH 2-Tube Bridge Rail. The flashbulb was visible from each camera. The video files from these digital high-speed cameras were analyzed to observe phenomena occurring during the collision and to obtain time-event, displacement, and angular data. A digital camera recorded and documented conditions of each test vehicle and the installation before and after the test.

*This page intentionally left blank.*

## Chapter 5. MASH TEST 4-12 (CRASH TEST NO. 608331-01-1A)

### 5.1 TEST DESIGNATION AND ACTUAL IMPACT CONDITIONS

MASH Test 4-12 involves a 10000S vehicle weighing 22,046 lb  $\pm$ 660 lb impacting the CIP of the bridge rail at an impact speed of 56 mi/h  $\pm$ 2.5 mi/h, and an angle of 15°  $\pm$ 1.5°. The target CIP for MASH Test 4-12 on the 2019 MASH 2-Tube Bridge Rail was 5.0 ft  $\pm$ 1 ft upstream of the centerline of post 5.

The 2011 International 4300 single-unit truck used in the test weighed 22,050 lb, and the actual impact speed and angle were 57.4 mi/h and 15.5°, respectively. The actual impact point was 4.6 ft upstream of the centerline of post 5. Minimum target impact severity (IS) was 142 kip-ft, and the actual IS was 173 kip-ft.

### 5.2 WEATHER CONDITIONS

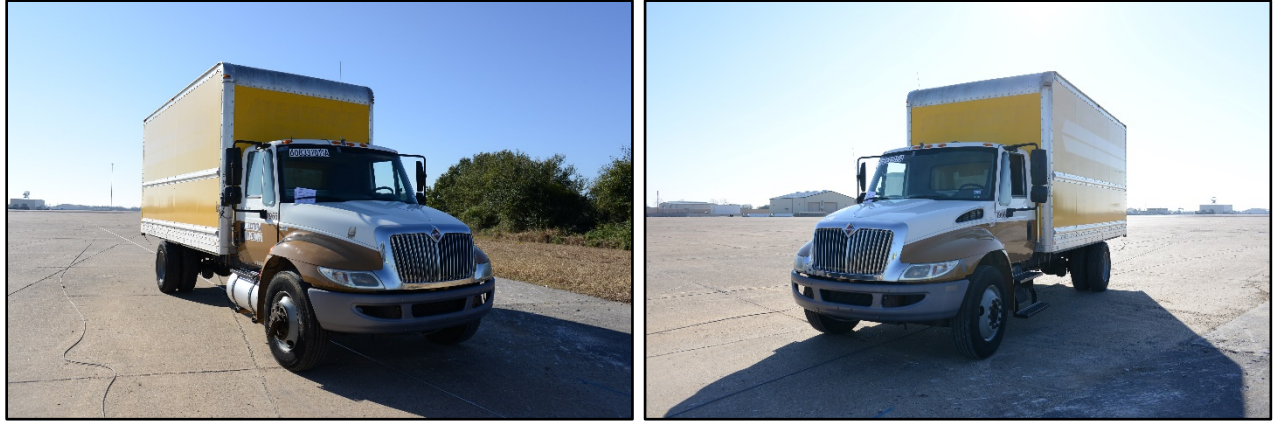
The test was performed on the morning of December 10, 2018. Weather conditions at the time of testing were as follows: wind speed: 4 mi/h; wind direction: 290° (vehicle was traveling in a northwesterly direction); temperature: 48°F; relative humidity: 75 percent.

### 5.3 TEST VEHICLE

Figures 5.1 and 5.2 show the 2011 International 4300 single-unit truck used for the crash test. The vehicle's test inertia weight was 22,050 lb, and its gross static weight was 22,050 lb. The height to the lower edge of the vehicle bumper was 19.0 inches, and height to the upper edge of the bumper was 34.0 inches. The height to the center of gravity of the vehicle's ballast was 61.25 inches. Tables C.1 in Appendix C1 give additional dimensions and information on the vehicle. The vehicle was directed into the installation using the cable reverse tow and guidance system, and was released to be freewheeling and unrestrained just prior to impact.



Figure 5.1. 2019 MASH 2-Tube Bridge Rail/Test Vehicle Geometrics for Test No. 608331-01-1A.



**Figure 5.2. Test Vehicle before Test No. 608331-01-1A.**

#### **5.4 TEST DESCRIPTION**

The test vehicle was traveling at an impact speed of 57.4 mi/h when it contacted the 2019 MASH 2-Tube Bridge Rail 4.6 ft upstream of the centerline of post 5, at an impact angle of 15.5°. Table 5.1 lists events that occurred during Test No. 608331-01-1A. Figures C.1 and C.2 in Appendix C2 present sequential photographs during the test.

**Table 5.1. Events during Test No. 608331-01-1A.**

<b>TIME (s)</b>	<b>EVENTS</b>
0.0000	Vehicle contacts bridge rail
0.0820	Vehicle begins to redirect
0.1140	Right front tire lifts from pavement
0.2450	Back left side of vehicle contacts barrier
0.3030	Vehicle is parallel with barrier
1.0310	Right front tire contacts pavement
1.5470	Vehicle loses contact with bridge rail (out of view of high-speed camera)

For longitudinal barriers, it is desirable that the vehicle redirects and exits the barrier within the exit box criteria (not less than 65.6 ft downstream from loss of contact for the 10000S vehicle). The test vehicle exited within the exit box criteria defined in *MASH*. After loss of contact with the barrier, the vehicle came to rest 232 ft downstream of the impact and 7 ft toward the field side of the installation.

#### **5.5 DAMAGE TO TEST INSTALLATION**

Figures 5.3 and 5.4 show the damage to the 2019 MASH 2-Tube Bridge Rail. The traffic face of the bridge rail was scuffed with tire marks, and the lower rail element was gouged in the impact area. The curb was cracked on the downstream side of post 5 and just upstream of post 5 (see Figure 5.4). Working width was 56.7 inches at a height of 136.8 inches. Maximum



dynamic deflection during the test was 3.0 inches, and maximum permanent deformation was 2.0 inches.



**Figure 5.3. Overall Damage to Alaska Bridge Rail after Test No. 608331-01-1A.**





**Figure 5.4. Impact Area after Test No. 608331-01-1A.**

## **5.6 VEHICLE DAMAGE**

Figure 5.5 shows the damage sustained by the vehicle. The front bumper, hood, left front tire and rim, left front U-bolts, left battery box, left side steps, left door, left rear cab corner, lower edge of box, and left rear outer tire and rim were damaged. Maximum exterior crush to the vehicle was 12.0 inches in the front plane at the left front corner at bumper height. Maximum occupant compartment deformation was 5.5 inches in the left front corner of the floor pan. Figure 5.6 shows the interior of the vehicle.





**Figure 5.5. Test Vehicle after Test No. 608331-01-1A.**



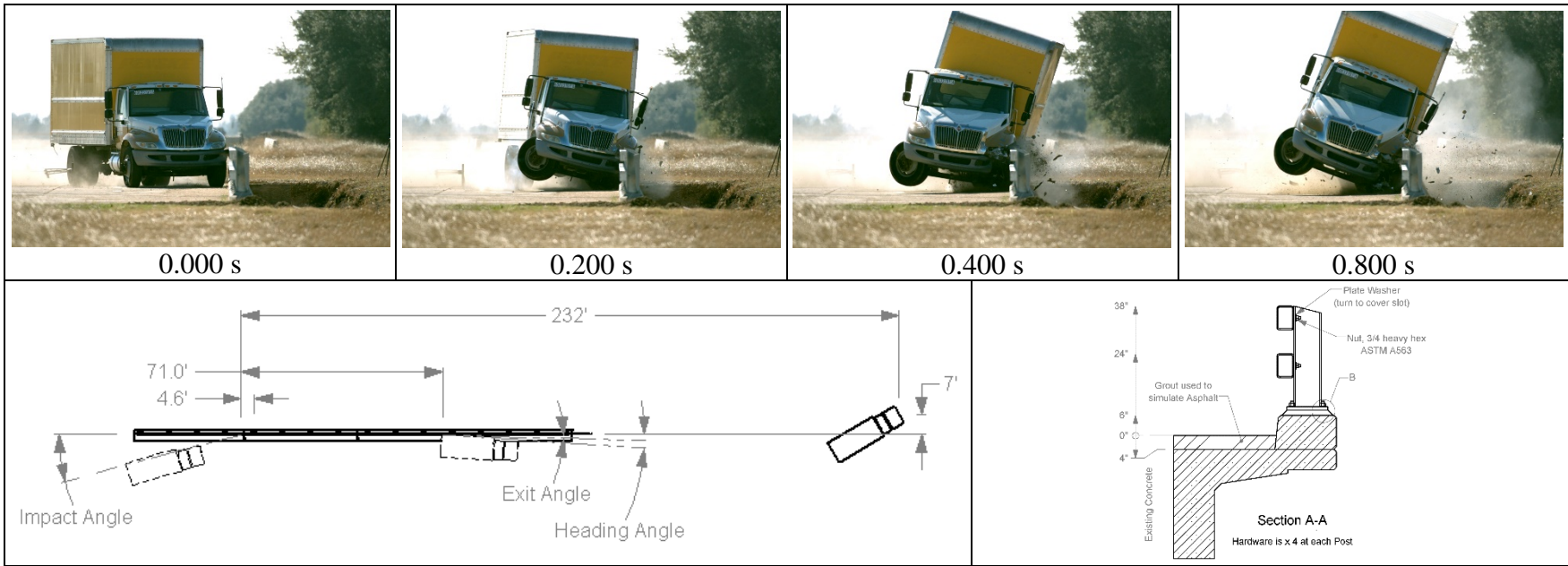
**Figure 5.6. Interior of Test Vehicle after Test No. 608331-01-1A.**

## **5.7 OCCUPANT RISK FACTORS**

Occupant risk factors are not required for the test with the 10000S vehicle. Data from the accelerometers, located at the vehicles longitudinal center of gravity, were digitized for information purposes only and results are shown in Table 5.2. Figure 5.7 summarizes these data and other pertinent information from the test. Figure C.3 in Appendix C3 shows the vehicle angular displacements, and Figures C.4 through C.9 in Appendix C4 show accelerations versus time traces.

**Table 5.2. Occupant Risk Factors for Test No. 608331-01-1A.**

<b>Occupant Risk Factor</b>	<b>Value</b>	<b>Time</b>
<b>Occupant Impact Velocity (OIV)</b> Longitudinal Lateral	<b>6.2 ft/s</b> <b>12.1 ft/s</b>	at 0.2057 s on left side of interior
<b>Occupant Ridedown Accelerations</b> Longitudinal Lateral	<b>3.0 g</b> <b>6.8 g</b>	0.4539 - 0.4639 s 0.2695 - 0.2795 s
<b>Theoretical Head Impact Velocity (THIV)</b>	<b>15.4 km/h</b> <b>4.3 m/s</b>	at 0.1995 s on left side of interior
<b>Post Head Deceleration (PHD)</b>	<b>6.9 g</b>	0.2695 - 0.2795 s
<b>Acceleration Severity Index (ASI)</b>	<b>0.43</b>	0.1106 - 0.1606 s
<b>Maximum 50-ms Moving Average</b> Longitudinal Lateral Vertical	<b>-1.6 g</b> <b>4.2 g</b> <b>-4.1 g</b>	0.0405 - 0.0905 s 0.2850 - 0.3350 s 0.2966 - 0.3466 s
<b>Maximum Roll, Pitch, and Yaw Angles</b> Roll Pitch Yaw	<b>19°</b> <b>9°</b> <b>19°</b>	0.4970 s 2.0000 s 0.5056 s



**General Information**

Test Agency..... Texas A&M Transportation Institute (TTI)  
 Test Standard Test No. .... MASH Test 4-12  
 TTI Test No. .... 608331-01-1A  
 Test Date ..... 2018-12-10

**Test Article**

Type ..... Bridge Rail  
 Name ..... 2019 MASH 2-Tube Bridge Rail  
 Installation Length..... 154 ft  
 Material or Key Elements... Two Steel Tubular Rail Elements on Fabricated Steel Posts spaced at 10 ft with 24-inch and 38-inch rail heights and mounted to concrete curb  
 Installed on Reinforced Concrete Bridge

**Soil Type and Condition** ..... Deck, Damp

**Test Vehicle**

10000S  
 Type/Designation ..... 2011 International 4300  
 Make and Model ..... 14,000 lb  
 Curb..... 22,050 lb  
 Test Inertial ..... No dummy  
 Dummy ..... 22,050 lb  
 Gross Static .....

**Impact Conditions**

Speed ..... 57.4 mi/h  
 Angle ..... 15.5°  
 Location/Orientation ..... 4.6 ft upstream of post 5

**Impact Severity**..... 173 kip-ft

**Exit Conditions**

Speed ..... Not obtainable  
 Angle ..... Not obtainable

**Occupant Risk Values**

Longitudinal OIV ..... 6.2 ft/s  
 Lateral OIV..... 12.1 ft/s  
 Longitudinal Ridedown..... 3.0 g  
 Lateral Ridedown ..... 6.8 g  
 THIV ..... 15.4 km/h  
 PHD ..... 6.9 g  
 ASI..... 0.43  
 Max. 0.050-s Average  
 Longitudinal ..... -1.6 g  
 Lateral..... 4.2 g  
 Vertical..... -4.1 g

**Post-Impact Trajectory**

Stopping Distance..... 232 ft downstream  
 7 ft twd field side

**Vehicle Stability**

Maximum Yaw Angle ..... 19°  
 Maximum Pitch Angle ..... 9°  
 Maximum Roll Angle ..... 19°  
 Vehicle Snagging ..... No  
 Vehicle Pocketing ..... No

**Test Article Deflections**

Dynamic..... 3.0 inches  
 Permanent ..... 2.0 inches  
 Working Width..... 56.7 inches  
 Height of Working Width ..... 136.8 inches

**Vehicle Damage**

VDS ..... NA  
 CDC..... 11FREW4  
 Max. Exterior Deformation..... 12.0 inches  
 OCDI..... NA  
 Max. Occupant Compartment Deformation ..... 5.5 inches

**Figure 5.7. Summary of Results for MASH Test 4-12 on 2019 MASH 2-Tube Bridge Rail.**

*This page intentionally left blank.*

## Chapter 6. MASH TEST 4-11 (CRASH TEST NO. 608331-01-2)

### 6.1 TEST DESIGNATION AND ACTUAL IMPACT CONDITIONS

MASH Test 4-11 involves a 2270P vehicle weighing 5000 lb  $\pm$ 110 lb impacting the CIP of the bridge rail at an impact speed of 62 mi/h  $\pm$ 2.5 mi/h and an angle of 25°  $\pm$ 1.5°. The target CIP for MASH Test 4-11 on the 2019 MASH 2-Tube Bridge Rail was 4.3  $\pm$ 1 ft upstream of the centerline of post 9.

The 2012 RAM 1500 pickup truck used in the test weighed 5019 lb, and the actual impact speed and angle were 62.9 mi/h and 24.9°, respectively. The actual impact point was 4.2 ft upstream of the centerline of post 9. Minimum target IS was 106 kip-ft, and the actual IS was 118 kip-ft.

### 6.2 WEATHER CONDITIONS

The test was performed on the morning of December 12, 2018. Weather conditions at the time of testing were as follows: wind speed: 9 mi/h; wind direction: 165° (vehicle was traveling in a northwesterly direction); temperature: 61°F; relative humidity: 87 percent.

### 6.3 TEST VEHICLE

Figures 6.1 and 6.2 show the 2012 RAM 1500 pickup truck used for the crash test. The vehicle's test inertia weight was 5019 lb, and its gross static weight was 5184 lb. The height to the lower edge of the vehicle bumper was 11.75 inches, and height to the upper edge of the bumper was 27.0 inches. The height to the vehicle's center of gravity was 29.0 inches. Tables D.1 and D.2 in Appendix D1 give additional dimensions and information on the vehicle. The vehicle was directed into the installation using the cable reverse tow and guidance system, and was released to be freewheeling and unrestrained just prior to impact.



Figure 6.1. 2019 MASH 2-Tube Bridge Rail/Test Vehicle Geometrics for Test No. 608331-01-2.





**Figure 6.2. Test Vehicle before Test No. 608331-01-2.**

#### 6.4 TEST DESCRIPTION

The test vehicle was traveling at an impact speed of 62.9 mi/h when it contacted the 2019 MASH 2-Tube Bridge Rail 4.2 ft upstream of the centerline of post 9 at an impact angle of 24.9°. Table 6.1 lists events that occurred during Test No. 608331-01-2. Figures D.1 and D.2 in Appendix D2 present sequential photographs during the test.

**Table 6.1. Events during Test No. 608331-01-2.**

<b>TIME (s)</b>	<b>EVENTS</b>
0.0000	Vehicle contacts barrier
0.0180	Lower metal rail element begins to deflect
0.0210	Upper metal rail element begins to deflect
0.0220	Vehicle begins to redirect
0.0290	Crack forms on downstream side of post 9 radiating from front bolt
0.0340	Bumper reaches post 9
0.0350	Crack forms on downstream side of post 9 radiating from rear bolt
0.0370	Crack forms on upstream side of post 9 radiating from rear bolt
0.0650	Crack forms on upstream side of post 8 radiating from front bolt
0.1670	Vehicle parallel with bridge rail
0.1720	Rear of vehicle contacts bridge rail
0.2800	Vehicle loses contact with bridge rail while traveling at 52.9 mi/h and exit trajectory/heading of 8.7°/6.5°

For longitudinal barriers, it is desirable that the vehicle redirects and exits the barrier within the exit box criteria (not less than 32.8 ft downstream from loss of contact for cars and pickups). The test vehicle exited within the exit box criteria defined in *MASH*. After loss of contact with the barrier, the vehicle came to rest 230 ft downstream of the impact with the nose of the vehicle in line with the traffic face of the bridge rail.

## 6.5 DAMAGE TO TEST INSTALLATION

Figures 6.3 and 6.4 show the damage to the 2019 MASH 2-Tube Bridge Rail. The metal rail elements were scuffed with tire marks and cosmetic damage. The concrete around the curb at post 8 was cracked. The concrete around post 9 was cracked and spalled off, revealing the rebar on the field side of the curb and on the underside of the deck. Working width was 20.2 inches at the top of post 9. Maximum dynamic deflection during the test was 7.1 inches, and maximum permanent deformation was 2.0 inches.



**Figure 6.3. 2019 MASH 2-Tube Bridge Rail after Test No. 608331-01-2.**





**Figure 6.4. Damage at Post 9 after Test No. 608331-01-2.**

## **6.6 VEHICLE DAMAGE**

Figure 6.5 shows the damage sustained by the vehicle. The front bumper, hood, grill, left tire and rim, left upper and lower A-arms, left upper and lower ball joints, left tie rod end, left front fender, left front and rear doors, left rear cab corner, left rear exterior bed, left rear rim, rear bumper, and tailgate were damaged. The windshield sustained stress cracks radiating up and out from the left lower corner. Maximum exterior crush to the vehicle was 11.0 inches in the side plane at the left front corner at bumper height. Maximum occupant compartment deformation



was 0.5 inch in the left front firewall area. Figure 6.6 shows the interior of the vehicle. Tables D.3 and D.4 in Appendix D1 provide exterior crush and occupant compartment measurements.



**Figure 6.5. Test Vehicle after Test No. 608331-01-2.**



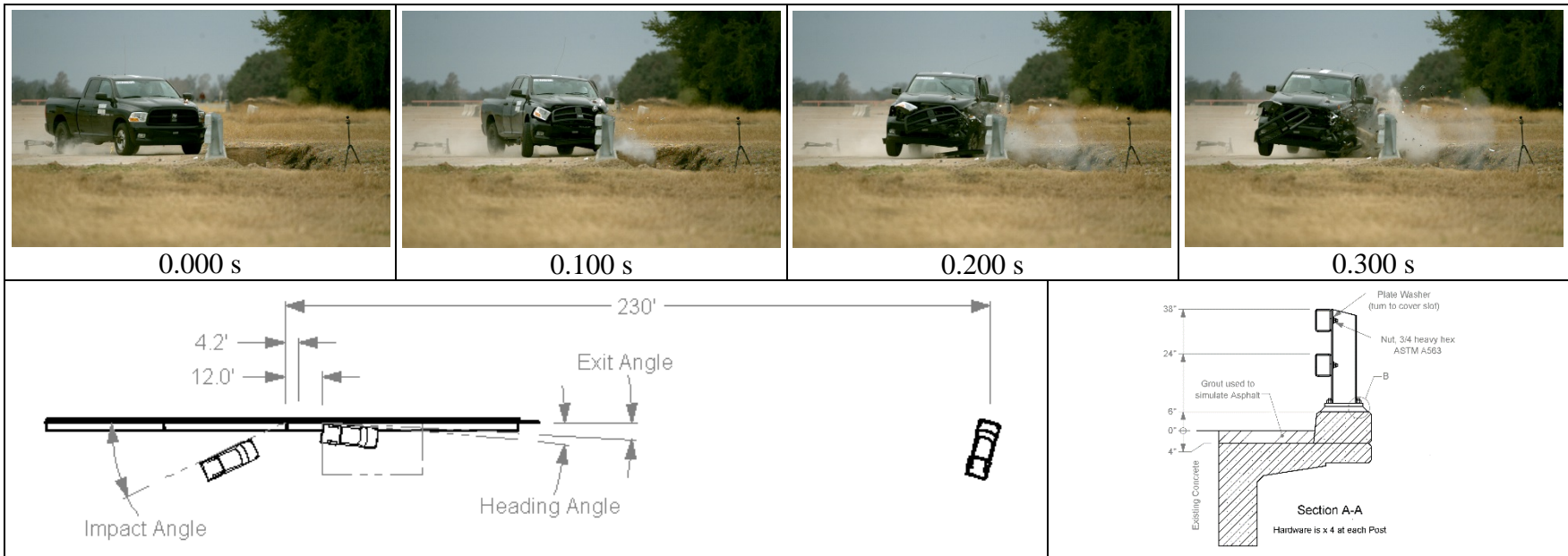
**Figure 6.6. Interior of Test Vehicle for Test No. 608331-01-2.**

## **6.7 OCCUPANT RISK FACTORS**

Data from the accelerometer, located at the vehicle center of gravity, were digitized for evaluation of occupant risk and results are shown in Table 6.2. Figure 6.7 summarizes these data and other pertinent information from the test. Figure D.3 in Appendix D3 shows the vehicle angular displacements, and Figures D.4 through D.9 in Appendix D4 show accelerations versus time traces.

**Table 6.2. Occupant Risk Factors for Test No. 608331-01-2.**

<b>Occupant Risk Factor</b>	<b>Value</b>	<b>Time</b>
<b>OIV</b> Longitudinal Lateral	<b>16.7 ft/s</b> <b>29.5 ft/s</b>	at 0.0957 s on left side of interior
<b>Occupant Ridedown Accelerations</b> Longitudinal Lateral	<b>8.2 g</b> <b>13.6 g</b>	0.1173 - 0.1273 s 0.2099 - 0.2199 s
<b>THIV</b>	<b>37.6 km/h</b> <b>10.5 m/s</b>	at 0.0933 s on left side of interior
<b>PHD</b>	<b>13.6 g</b>	0.2099 - 0.2199 s
<b>ASI</b>	<b>2.21</b>	0.0626 - 0.1126 s
<b>Maximum 50-ms Moving Average</b> Longitudinal Lateral Vertical	<b>-7.9 g</b> <b>17.0 g</b> <b>3.7 g</b>	0.0276 - 0.0776 s 0.0421 - 0.0921 s 0.0815 - 0.1315 s
<b>Maximum Roll, Pitch, and Yaw Angles</b> Roll Pitch Yaw	<b>5°</b> <b>3°</b> <b>33°</b>	0.3752 s 0.4918 s 0.4177 s



**General Information**

Test Agency ..... Texas A&M Transportation Institute (TTI)  
 Test Standard Test No. .... MASH Test 4-11  
 TTI Test No. .... 608331-01-2  
 Test Date ..... 2018-12-12

**Test Article**

Type ..... Bridge Rail  
 Name ..... 2019 MASH 2-Tube Bridge Rail  
 Installation Length ..... 154 ft  
 Material or Key Elements ... Two Steel Tubular Rail Elements on Fabricated Steel Posts spaced at 10 ft with 24-inch and 38-inch rail heights and mounted to concrete curb Installed on Reinforced Concrete Bridge Installed on

**Soil Type and Condition** .... Deck, Damp

**Test Vehicle**

Type/Designation ..... 2270P  
 Make and Model ..... 2012 RAM 1500 Pickup  
 Curb ..... 4902 lb  
 Test Inertial ..... 5019 lb  
 Dummy ..... 165 lb  
 Gross Static ..... 5184 lb

**Impact Conditions**

Speed ..... 62.9 mi/h  
 Angle ..... 24.9°  
 Location/Orientation ..... 4.2 ft upstream of post 9

**Impact Severity**

..... 118 kip-ft  
**Exit Conditions**  
 Speed ..... 52.9 mi/h  
 Exit Trajectory/Heading ..... 8.7°/6.5°

**Occupant Risk Values**

Longitudinal OIV ..... 16.7 ft/s  
 Lateral OIV ..... 29.5 ft/s  
 Longitudinal Ridedown ..... 8.2 g  
 Lateral Ridedown ..... 13.6 g  
 THIV ..... 37.6 km/h  
 PHD ..... 13.6 g  
 ASI ..... 2.21  
 Max. 0.050-s Average  
 Longitudinal ..... -7.9 g  
 Lateral ..... 17.0 g  
 Vertical ..... 3.7 g

**Post-Impact Trajectory**

Stopping Distance ..... 230 ft downstream

**Vehicle Stability**

Maximum Yaw Angle ..... 33°  
 Maximum Pitch Angle ..... 3°  
 Maximum Roll Angle ..... 5°  
 Vehicle Snagging ..... No  
 Vehicle Pocketing ..... No

**Test Article Deflections**

Dynamic ..... 7.1 inches  
 Permanent ..... 2.0 inches  
 Working Width ..... 20.2 inches  
 Height of Working Width ..... 38 inches, or Top

**Vehicle Damage**

VDS ..... of post  
 CDC ..... 11LFQ5  
 Max. Exterior Deformation ..... 11FLEW4  
 OCDI ..... 11.0 inches  
 Max. Occupant Compartment Deformation ..... LF0010000  
 ..... 0.5 inch

**Figure 6.7. Summary of Results for MASH Test 4-11 on 2019 MASH 2-Tube Bridge Rail.**

*This page intentionally left blank.*

## Chapter 7. MASH TEST 4-10 (CRASH TEST NO. 608331-01-3)

### 7.1 TEST DESIGNATION AND ACTUAL IMPACT CONDITIONS

MASH Test 4-10 involves an 1100C vehicle weighing 2420 lb  $\pm$ 55 lb impacting the CIP of the 2019 MASH 2-Tube Bridge Rail at an impact speed of 62 mi/h  $\pm$ 2.5 mi/h and an angle of 25°  $\pm$ 1.5°. The target CIP for MASH Test 4-10 on the 2019 MASH 2-Tube Bridge Rail was 3.6 ft  $\pm$ 1 ft upstream of the centerline of post 13.

The 2010 Kia Rio\* used in the test weighed 2454 lb, and the actual impact speed and angle were 62.5 mi/h and 25.3°, respectively. The actual impact point was 3.5 ft upstream of the centerline of post 13. Minimum target IS was 51 kip-ft, and the actual IS was 58 kip-ft.

### 7.2 WEATHER CONDITIONS

The test was performed on the morning of December 14, 2018. Weather conditions at the time of testing were as follows: wind speed: 13 mi/h; wind direction: 309 degrees (vehicle was traveling in a northwesterly direction); temperature: 46°F; relative humidity: 86 percent.

### 7.3 TEST VEHICLE

Figures 7.1 and 7.2 show the 2010 Kia Rio used for the crash test. The vehicle's test inertia weight was 2454 lb, and its gross static weight was 2619 lb. The height to the lower edge of the vehicle bumper was 7.75 inches, and height to the upper edge of the bumper was 21.5 inches. Table E.1 in Appendix E1 gives additional dimensions and information on the vehicle. The vehicle was directed into the installation using the cable reverse tow and guidance system, and was released to be freewheeling and unrestrained just prior to impact.



Figure 7.1. 2019 MASH 2-Tube Bridge Rail/Test Vehicle Geometrics for Test No. 608331-01-3.

---

\* The 2010 model vehicle used is older than the 6-year age noted in MASH, and was selected based upon availability. An older model vehicle is permitted by AASHTO as long as it is otherwise MASH compliant. Other than the vehicle's year model, this 2010 model vehicle met the MASH requirements.





**Figure 7.2. Test Vehicle before Test No. 608331-01-3.**

#### **7.4 TEST DESCRIPTION**

The test vehicle was traveling at an impact speed of 62.5 mi/h when it contacted the 2019 MASH 2-Tube Bridge Rail 3.5 ft upstream of the centerline of post 13 at an impact angle of 25.3°. Table 7.1 lists events that occurred during Test No. 608331-01-3. Figures E.1 and E.2 in Appendix E2 present sequential photographs during the test.

**Table 7.1. Events during Test No. 608331-01-3.**

<b>TIME (s)</b>	<b>EVENTS</b>
0.0000	Vehicle impacts bridge rail
0.0160	Metal rail element begins to deflect
0.0240	Vehicle begins to redirect
0.0280	Bumper reaches post 13
0.0840	Dummy's head shatters left front door glass
0.1180	Dummy's head at max extension out of vehicle, but no contact with rail
0.2190	Vehicle parallel with bridge rail
0.2350	Rear of vehicle contacts bridge rail
0.3130	Vehicle loses contact with bridge rail while traveling at 45.3 mi/h and exit trajectory/heading of 4.8°/6.0°

For longitudinal barriers, it is desirable that the vehicle redirects and exits the barrier within the exit box criteria (not less than 32.8 ft downstream from loss of contact for cars and pickups). The test vehicle exited within the exit box criteria defined in *MASH*. After loss of contact with the barrier, the vehicle came to rest 140 ft downstream of the impact and 11 ft toward the field side.

#### **7.5 DAMAGE TO TEST INSTALLATION**

Figure 7.3 and 7.4 show the damage to the 2019 MASH 2-Tube Bridge Rail. The metal rail elements were scuffed with tire marks and cosmetic damage. The concrete around the base



of post 13 was broken through the curb on both sides of the post and extended to the bottom of the deck. Working width was 8.5 inches at a height of 44.3 inches. Maximum dynamic deflection during the test was 2.8 inches, and maximum permanent deformation was 1.0 inch.



**Figure 7.3. 2019 MASH 2-Tube Bridge Rail after Test No. 608331-01-3.**



**Figure 7.4. Damage at Post 13 after Test No. 608331-01-3.**

## **7.6 VEHICLE DAMAGE**

Figure 7.5 shows the damage sustained by the vehicle. The front bumper, hood, radiator and support, left front fender, left front tire and rim, left front strut and tower, left A-post, roof, left front door and window glass, left rear door, left rear quarter panel, and rear bumper were damaged. The windshield sustained stress cracks radiating upward and outward from the left lower corner. Maximum exterior crush to the vehicle was 11.0 inches in the side plane at the left front corner at bumper height. Maximum occupant compartment deformation was 4.0 inches in the left front firewall area. Figure 7.6 shows the interior of the vehicle. Tables E.2 and E.3 in Appendix E1 provide exterior crush and occupant compartment measurements.





**Figure 7.5. Test Vehicle after Test No. 608331-01-3.**



**Figure 7.6. Interior of Test Vehicle for Test No. 608331-01-3.**

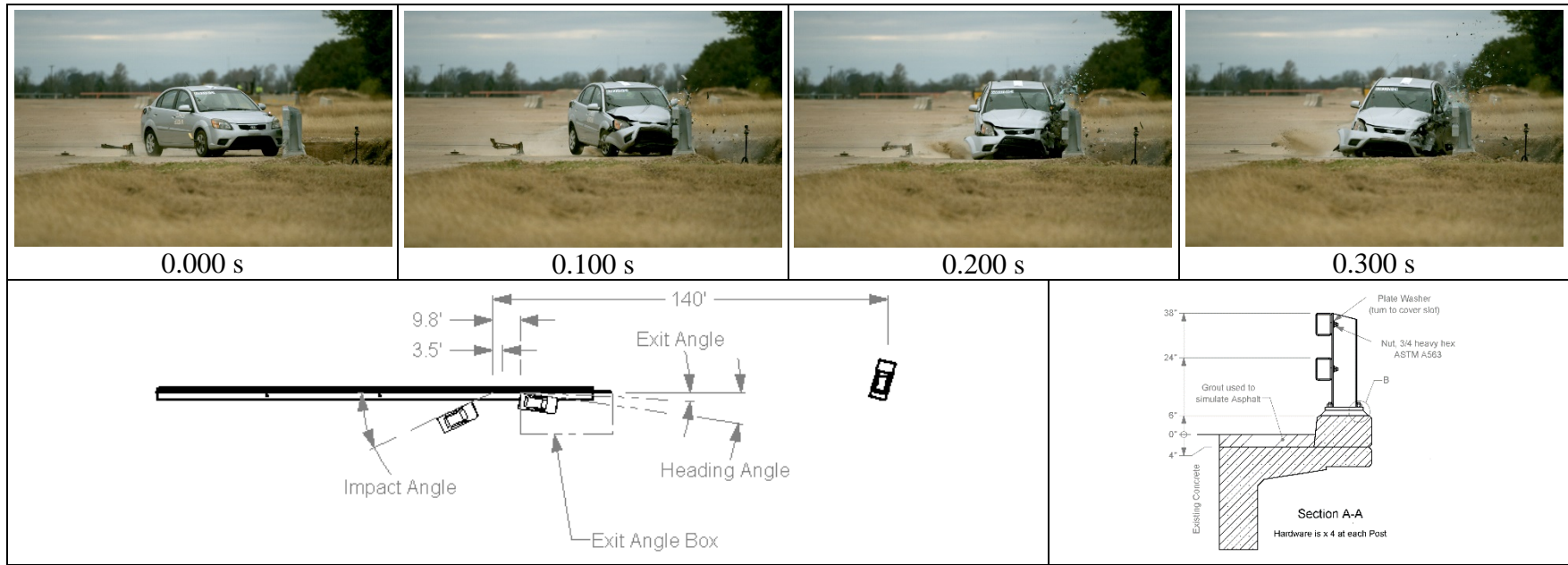
## **7.7 OCCUPANT RISK FACTORS**

Data from the accelerometer, located at the vehicle center of gravity, were digitized for evaluation of occupant risk and results are shown in Table 7.2. Figure 7.7 summarizes these data and other pertinent information from the test. Figure E.3 in Appendix E3 shows the

vehicle angular displacements, and Figures E.4 through E.9 in Appendix E4 show accelerations versus time traces.

**Table 7.2. Occupant Risk Factors for Test No. 608331-01-3.**

<b>Occupant Risk Factor</b>	<b>Value</b>	<b>Time</b>
<b>OIV</b> Longitudinal Lateral	<b>30.2 ft/s</b> <b>30.8 ft/s</b>	at 0.0741 s on left side of interior
<b>Occupant Ridedown Accelerations</b> Longitudinal Lateral	<b>15.3 g</b> <b>6.3 g</b>	0.1513 - 0.1613 s 0.1556 - 0.1656 s
<b>THIV</b>	<b>46.9 km/h</b> <b>13.0 m/s</b>	at 0.0723 s on left side of interior
<b>PHD</b>	<b>16.4 g</b>	0.1512 - 0.1612 s
<b>ASI</b>	<b>2.65</b>	0.0459 - 0.0959 s
<b>Maximum 50-ms Moving Average</b> Longitudinal Lateral Vertical	<b>-17.3 g</b> <b>18.4 g</b> <b>-3.3g</b>	0.0256 - 0.0756 s 0.0166 - 0.0666 s 0.0244 - 0.0744 s
<b>Maximum Roll, Pitch, and Yaw Angles</b> Roll Pitch Yaw	<b>5°</b> <b>5°</b> <b>34°</b>	0.5011 s 0.3087 s 0.4335 s



**General Information**

Test Agency..... Texas A&M Transportation Institute (TTI)  
 Test Standard Test No. .... MASH Test 4-10  
 TTI Test No. .... 608331-01-3  
 Test Date ..... 2018-12-14

**Test Article**

Type ..... Bridge Rail  
 Name ..... 2019 MASH 2-Tube Bridge Rail  
 Installation Length..... 154 ft  
 Material or Key Elements... Two Steel Tubular Rail Elements on Fabricated Steel Posts spaced at 10 ft with 24-inch and 38-inch rail heights and mounted to concrete curb Installed on Reinforced Concrete Bridge

**Soil Type and Condition** ..... Deck, Damp

**Test Vehicle**

Type/Designation..... 1100C  
 Make and Model ..... 2010 Kia Rio  
 Curb..... 2484 lb  
 Test Inertial..... 2454 lb  
 Dummy ..... 165 lb  
 Gross Static ..... 2619 lb

**Impact Conditions**

Speed ..... 62.5 mi/h  
 Angle ..... 25.3°  
 Location/Orientation ..... 3.5 ft upstream of post 13

**Impact Severity**..... 58 kip-ft

**Exit Conditions**

Speed ..... 45.3 mi/h  
 Exit Trajectory/Heading ..... 4.8°/6.0°

**Occupant Risk Values**

Longitudinal OIV ..... 30.2 ft/s  
 Lateral OIV..... 30.8 ft/s  
 Longitudinal Ridedown..... 15.3 g  
 Lateral Ridedown ..... 6.3 g  
 THIV ..... 46.9 km/h  
 PHD ..... 16.4 g  
 ASI..... 2.65

**Max. 0.050-s Average**

Longitudinal ..... -17.3 g  
 Lateral..... 18.4 g  
 Vertical..... -3.3 g

**Post-Impact Trajectory**

Stopping Distance..... 140 ft downstream  
 11 ft twd field side

**Vehicle Stability**

Maximum Yaw Angle ..... 34°  
 Maximum Pitch Angle ..... 5°  
 Maximum Roll Angle ..... 5°  
 Vehicle Snagging ..... No  
 Vehicle Pocketing ..... No

**Test Article Deflections**

Dynamic..... 2.8 inches  
 Permanent ..... 1.0 inch  
 Working Width..... 8.5 inches  
 Height of Working Width ..... 44.3 inches

**Vehicle Damage**

VDS ..... 11LFQ5  
 CDC..... 11FLEW4  
 Max. Exterior Deformation..... 11.0 inches  
 OCDI..... LF0030000  
 Max. Occupant Compartment Deformation ..... 4.0 inches

**Figure 7.7. Summary of Results for MASH Test 4-10 on 2019 MASH 2-Tube Bridge Rail.**



*This page intentionally left blank.*

## **Chapter 8. SUMMARY AND CONCLUSIONS**

### **8.1 ASSESSMENT OF TEST RESULTS**

The crash tests reported herein were performed in accordance with *MASH* TL4, which involves three tests on the 2019 *MASH* 2-Tube Bridge Rail. An assessment of each test based on the applicable safety evaluation criteria for *MASH* TL-4 for longitudinal barriers is provided in Tables 8.1 through 8.3.

### **8.2 CONCLUSIONS**

The 2019 *MASH* 2-Tube Bridge Rail performed acceptably for *MASH* TL-4 longitudinal barriers, as shown in Table 8.4.

**Table 8.1. Performance Evaluation Summary for MASH Test 4-12 on 2019 MASH 2-Tube Bridge Rail.**

Test Agency: Texas A&amp;M Transportation Institute

Test No.: 608331-01-1A

Test Date: 2018-12-10

<b>MASH Test 4-12 Evaluation Criteria</b>	<b>Test Results</b>	<b>Assessment</b>
<p><b><u>Structural Adequacy</u></b></p> <p>A. <i>Test article should contain and redirect the vehicle or bring the vehicle to a controlled stop; the vehicle should not penetrate, underride, or override the installation although controlled lateral deflection of the test article is acceptable.</i></p>	The 2019 MASH 2-Tube Bridge Rail contained and redirected the 10000S vehicle. The vehicle did not penetrate, underride, or override the installation. Maximum dynamic deflection of the metal rail elements during the test was 3.0 inches.	Pass
<p><b><u>Occupant Risk</u></b></p> <p>D. <i>Detached elements, fragments, or other debris from the test article should not penetrate or show potential for penetrating the occupant compartment, or present an undue hazard to other traffic, pedestrians, or personnel in a work zone.</i></p>	No detached elements, fragments, or other debris were present to penetrate or show potential for penetrating the occupant compartment, or to present undue hazard to others in the area.	Pass
<p><i>Deformations of, or intrusions into, the occupant compartment should not exceed limits set forth in Section 5.2.2 and Appendix E of MASH.</i></p>	Maximum occupant compartment deformation was 5.5 inches in the left front corner of the floor pan.	Pass
<p>G. <i>It is preferable, although not essential, that the vehicle remain upright during and after collision.</i></p>	The 10000S vehicle remained upright during and after the collision event.	Pass
<p><b><u>Vehicle Trajectory</u></b></p> <p>For redirective devices, it is preferable that the vehicle be smoothly redirected and leave the barrier within the “exit box” criteria (not less than 65.6 ft for the 10000S vehicle), and should be documented.</p>	The 10000S vehicle exited within the exit box criteria.	Documentation only

**Table 8.2. Performance Evaluation Summary for MASH Test 4-11 on 2019 MASH 2-Tube Bridge Rail.**

Test Agency: Texas A&amp;M Transportation Institute

Test No.: 608331-01-2

Test Date: 2018-12-12

<b>MASH Test 4-11 Evaluation Criteria</b>	<b>Test Results</b>	<b>Assessment</b>
<b><u>Structural Adequacy</u></b>		
A. <i>Test article should contain and redirect the vehicle or bring the vehicle to a controlled stop; the vehicle should not penetrate, underride, or override the installation although controlled lateral deflection of the test article is acceptable.</i>	The 2019 MASH 2-Tube Bridge Rail contained and redirected the 2270P vehicle. The vehicle did not penetrate, underride, or override the installation. Maximum dynamic deflection of the metal rail elements during the test was 7.1 inches.	Pass
<b><u>Occupant Risk</u></b>		
D. <i>Detached elements, fragments, or other debris from the test article should not penetrate or show potential for penetrating the occupant compartment, or present an undue hazard to other traffic, pedestrians, or personnel in a work zone.</i>	Some spalling of the concrete curb and deck on the field side occurred during the test; however, this debris did not penetrate or show potential for penetrating the occupant compartment, or to present undue hazard to others in the area.	Pass
<i>Deformations of, or intrusions into, the occupant compartment should not exceed limits set forth in Section 5.2.2 and Appendix E of MASH.</i>	Maximum occupant compartment deformation was 0.5 inches in the left front firewall area.	Pass
F. <i>The vehicle should remain upright during and after collision. The maximum roll and pitch angles are not to exceed 75 degrees.</i>	The 2270P vehicle remained upright during and after the collision event. Maximum roll and pitch angles were 5° and 3°, respectively.	Pass
H. <i>Occupant impact velocities (OIV) should satisfy the following limits: Preferred value of 30 ft/s, or maximum allowable value of 40 ft/s.</i>	Maximum longitudinal OIV was 16.7 ft/s, and maximum lateral OIV was 29.5 ft/s	Pass
I. <i>The occupant ridedown accelerations should satisfy the following limits: Preferred value of 15.0 g, or maximum allowable value of 20.49 g.</i>	Longitudinal occupant ridedown acceleration was 8.2 g, and lateral occupant ridedown acceleration was 13.6 g	Pass
<b><u>Vehicle Trajectory</u></b>		
For redirective devices, it is preferable that the vehicle be smoothly redirected and leave the barrier within the “exit box” criteria (not less than 32.8 ft for the 1100C and 2270P vehicles), and should be documented.	The 2270P vehicle exited within the exit box criteria.	Documentation only

**Table 8.3. Performance Evaluation Summary for MASH Test 4-10 on 2019 MASH 2-Tube Bridge Rail.**

Test Agency: Texas A&amp;M Transportation Institute

Test No.: 608331-01-3

Test Date: 2018-12-14

<b>MASH Test 4-10 Evaluation Criteria</b>	<b>Test Results</b>	<b>Assessment</b>
<b><u>Structural Adequacy</u></b>		
A. <i>Test article should contain and redirect the vehicle or bring the vehicle to a controlled stop; the vehicle should not penetrate, underride, or override the installation although controlled lateral deflection of the test article is acceptable.</i>	The 2019 MASH 2-Tube Bridge Rail contained and redirected the 1100C vehicle. The vehicle did not penetrate, underride, or override the installation. Maximum dynamic deflection of the metal rail elements during the test was 2.8 inches.	Pass
<b><u>Occupant Risk</u></b>		
D. <i>Detached elements, fragments, or other debris from the test article should not penetrate or show potential for penetrating the occupant compartment, or present an undue hazard to other traffic, pedestrians, or personnel in a work zone.</i>	Slight spalling of the concrete deck occurred at post 13 during the test; however, this debris did not penetrate or show potential for penetrating the occupant compartment, or to present undue hazard to others in the area.	Pass
<i>Deformations of, or intrusions into, the occupant compartment should not exceed limits set forth in Section 5.2.2 and Appendix E of MASH.</i>	Maximum occupant compartment deformation was 4.0 inches in the left front firewall area.	Pass
F. <i>The vehicle should remain upright during and after collision. The maximum roll and pitch angles are not to exceed 75 degrees.</i>	The 1100C vehicle remained upright during and after the collision event. Maximum roll and pitch angles were 5° each.	Pass
H. <i>Occupant impact velocities (OIV) should satisfy the following limits: Preferred value of 30 ft/s, or maximum allowable value of 40 ft/s.</i>	Maximum longitudinal OIV was 30.2 ft/s, and maximum lateral OIV was 30.8 ft/s	Pass
I. <i>The occupant ridedown accelerations should satisfy the following limits: Preferred value of 15.0 g, or maximum allowable value of 20.49 g.</i>	Longitudinal occupant ridedown acceleration was 15.3 g, and lateral occupant ridedown acceleration was 6.3 g	Pass
<b><u>Vehicle Trajectory</u></b>		
For redirective devices, it is preferable that the vehicle be smoothly redirected and leave the barrier within the “exit box” criteria (not less than 32.8 ft for the 1100C and 2270P vehicles), and should be documented.	The 1100C vehicle exited within the exit box criteria.	Documentation only



**Table 8.4. Assessment Summary for MASH TL-4 Tests  
on 2019 MASH 2-Tube Bridge Rail.**

<b>Evaluation Factors</b>	<b>Evaluation Criteria</b>	<b>Test No. 608331-01-3</b>	<b>Test No. 608331-01-2</b>	<b>Test No. 608331-01-1A</b>
<b>Structural Adequacy</b>	A	S	S	S
<b>Occupant Risk</b>	D	S	S	S
	F	S	S	N/A
	G	N/A	N/A	S
	H	S	S	N/A
	I	S	S	N/A
	<b>Test No.</b>	<b>MASH Test 4-10</b>	<b>MASH Test 4-11</b>	<b>MASH Test 4-12</b>
	<b>Pass/Fail</b>	Pass	Pass	Pass

S = Satisfactory  
U = Unsatisfactory  
N/A = Not Applicable

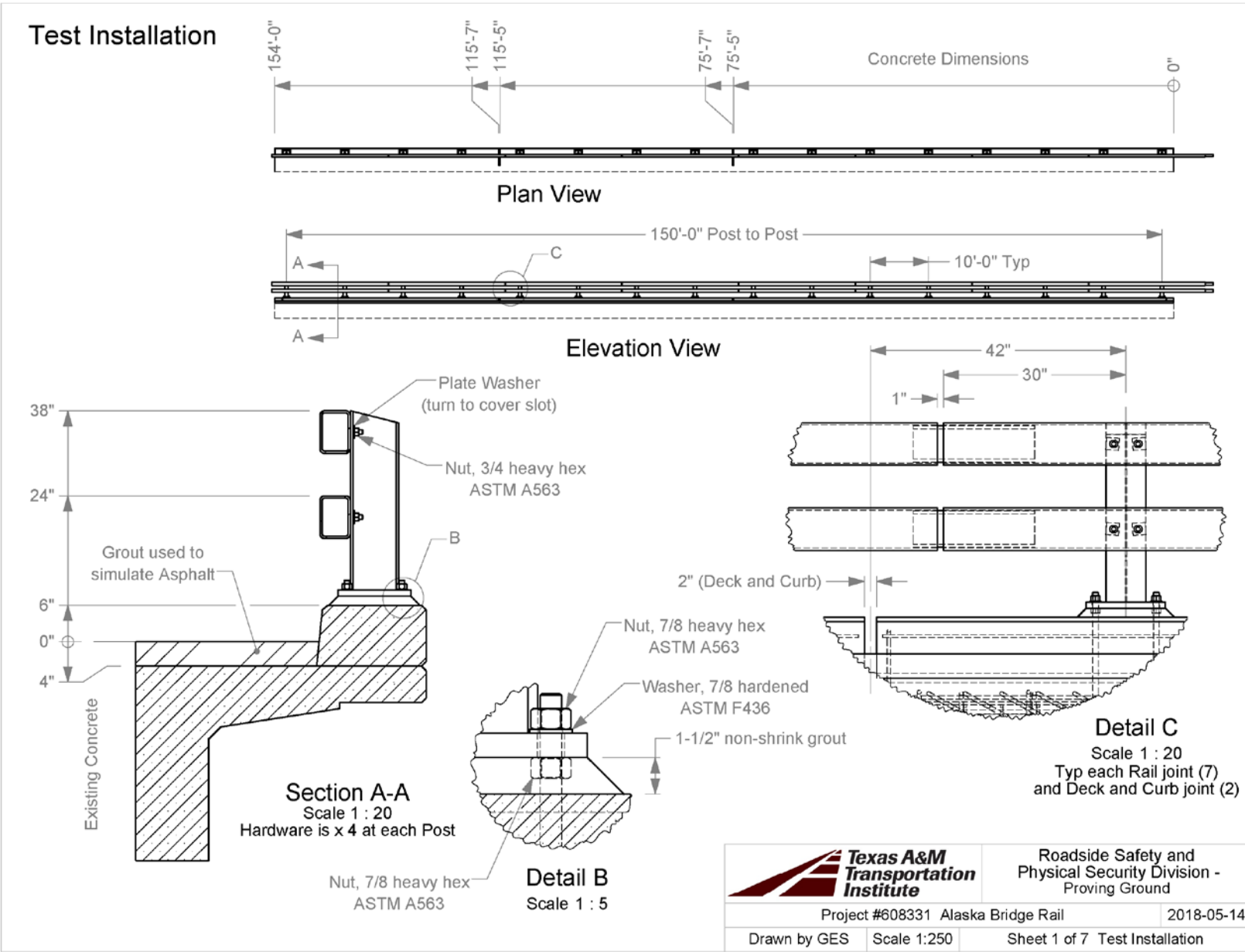
*This page intentionally left blank.*

## REFERENCES

1. AASHTO/FHWA Joint Implementation Agreement for Manual for Assessing Safety Hardware (MASH).  
[https://safety.fhwa.dot.gov/roadway\\_dept/countermeasures/reduce\\_crash\\_severity/docs/memo\\_joint\\_implementation\\_agmt.pdf](https://safety.fhwa.dot.gov/roadway_dept/countermeasures/reduce_crash_severity/docs/memo_joint_implementation_agmt.pdf), January 7, 2016, last access January 2019.
2. AASHTO. *Manual for Assessing Roadside Safety Hardware, Second Edition*. 2016, American Association of State Highway and Transportation Officials: Washington, D.C.
3. H. E. Ross, D. L. Sicking, R. A. Zimmer, and J. D. Michie, *Recommended Procedures for the Safety Performance Evaluation of Highway Features*, National Cooperative Highway Research Program Report 350, Transportation Research Board, National Research Council, Washington, D.C., 1993.
4. C. E. Buth, W. F. Williams, W. L. Menges, and S. K. Schoeneman. *NCHRP Report 350 Test 4-10 of the Alaska Multi-State Bridge Rail*, Test Report No.; 404311-1, Texas A&M Transportation Institute, College Station, TX, December 1998.
5. C. E. Buth, W. F. Williams, W. L. Menges, and S. K. Schoeneman. *NCHRP Report 350 Test 4-11 of the Alaska Multi-State Bridge Rail*, Test Report No.; 404311-2, Texas A&M Transportation Institute, College Station, TX, December 1998.
6. C. E. Buth, W. F. Williams, W. L. Menges, and S. K. Schoeneman. *NCHRP Report 350 Test 4-12 of the Alaska Multi-State Bridge Rail*, Test Report No.; 404311-3, Texas A&M Transportation Institute, College Station, TX, February 1998.
7. C. E. Buth, W. F. Williams, W. L. Menges, and S. K. Schoeneman. *NCHRP Report 350 Test 4-21 of the Alaska Multi-State Bridge Rail Thrie-Beam Transition*, Test Report No.; 404311-5, Texas A&M Transportation Institute, College Station, TX, July 1999.
8. C. E. Buth, W. F. Williams, W. L. Menges, and S. K. Schoeneman. *NCHRP Report 350 Test 4-22 of the Alaska Multi-State Bridge Rail Thrie-Beam Transition*, Test Report No.; 404311-6, Texas A&M Transportation Institute, College Station, TX, July 1999.
9. C. E. Buth, W. F. Williams, W. L. Menges, and S. K. Schoeneman. *NCHRP Report 350 Test 3-21 of the Alaska Multi-State Bridge Rail W-Beam Transition*, Test Report No.; 404311-7, Texas A&M Transportation Institute, College Station, TX, July 2000.
10. C. E. Buth, W. F. Williams, W. L. Menges, and S. K. Schoeneman. *NCHRP Report 350 Test 3-20 of the Alaska Multi-State Bridge Rail W-Beam Transition*, Test Report No.; 404311-8, Texas A&M Transportation Institute, College Station, TX, August 2000.

*This page intentionally left blank.*

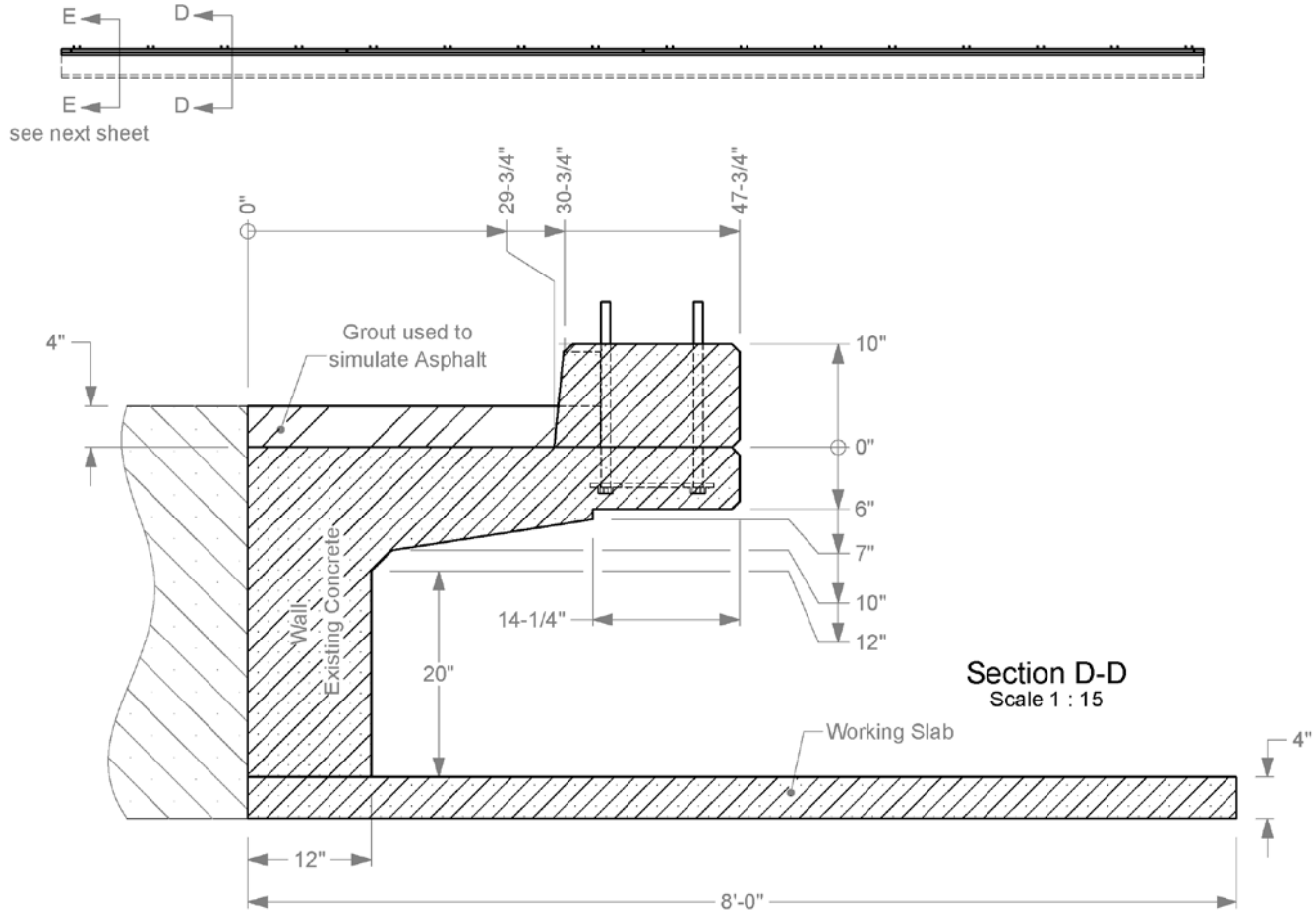
APPENDIX A. DETAILS OF THE 2019 MASH 2-TUBE BRIDGE RAIL



T:\ProjectFiles\608331 - Alaska - Williams\Drafting, 608331-1-3\608331 Drawing



Details, Elevation



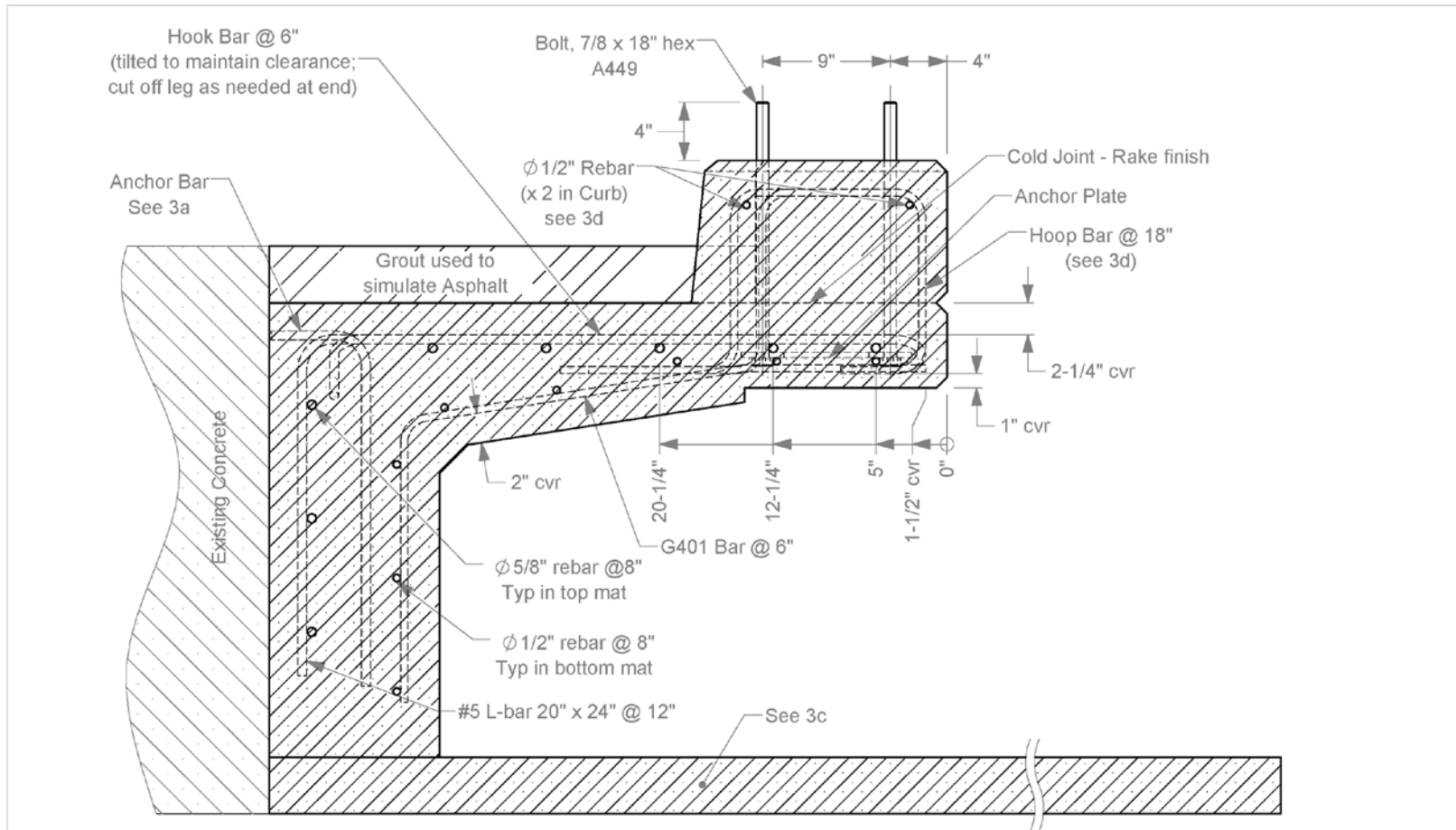
**2a.** Concrete Strength is 5000psi for the Wall and Deck, 3000 psi for the Working Slab, and 4000 psi for the Curb.

**2b.** Chamfer Field Side edges of Deck, and field side and top edges of end of Curb 3/4" each way as shown.



Roadside Safety and Physical Security Division - Proving Ground

Project #608331 Alaska Bridge Rail		2018-05-14
Drawn by GES	Scale 1:250	Sheet 2 of 7 Details, Elevation

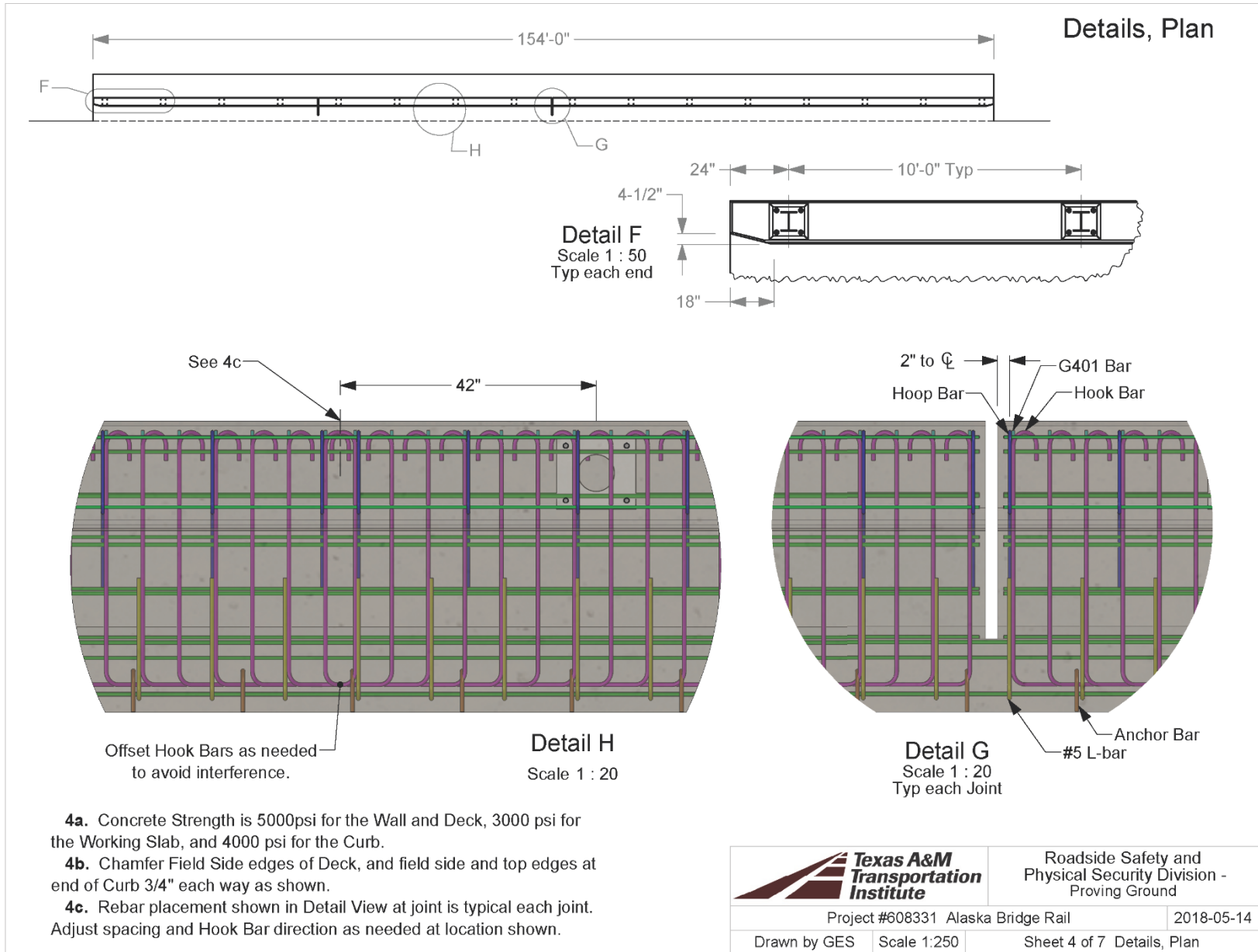


- 3a.** Place the Anchor Bars @ maximum 18" spacing and secure to existing rebar protruding from the runway with minimum 3" weld. (Existing rebar not shown here.)
- 3b.** Minimum rebar lap is 24" for #4 bars and 30" for #5 bars.
- 3c.** Place one mat of Ø1/2" (#4) bars in Working Slab @ 12" each way with ≈1-1/2" cover at top. These bars are not shown here.
- 3d.** Field bend traffic side longitudinal bar and turn Hoop Bars at ends of Curb to maintain cover.
- 3e.** The Anchor Bars will be bare steel, and the bars in the Working Slab may be bare steel. All other bars shall be epoxy coated, and all bars are grade 60.

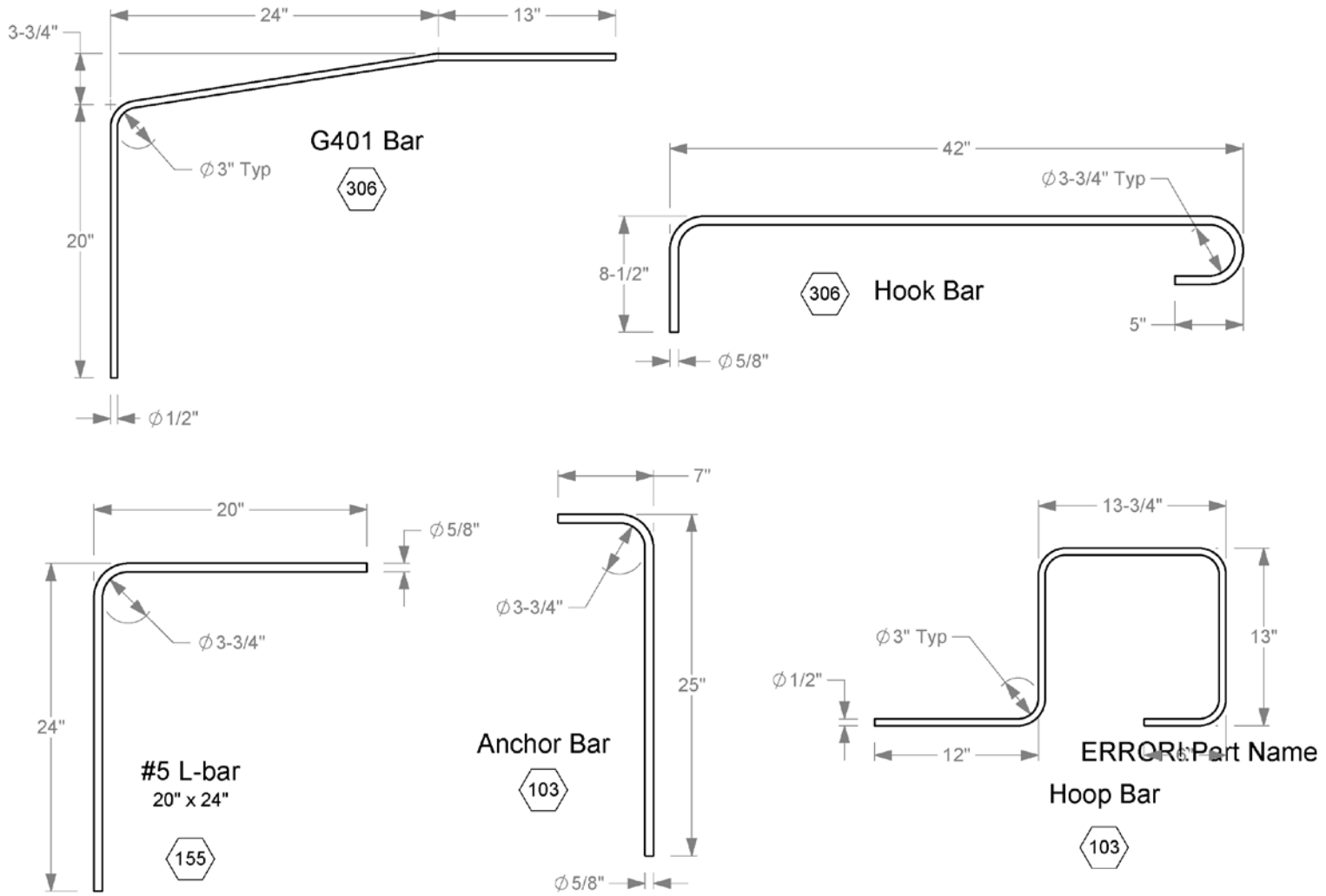
**Section E-E**

Scale 1 : 10

	Roadside Safety and Physical Security Division - Proving Ground	
	Project #608331 Alaska Bridge Rail	2018-05-14
Drawn by GES	Scale 1:10	Sheet 3 of 7 Rebar Details

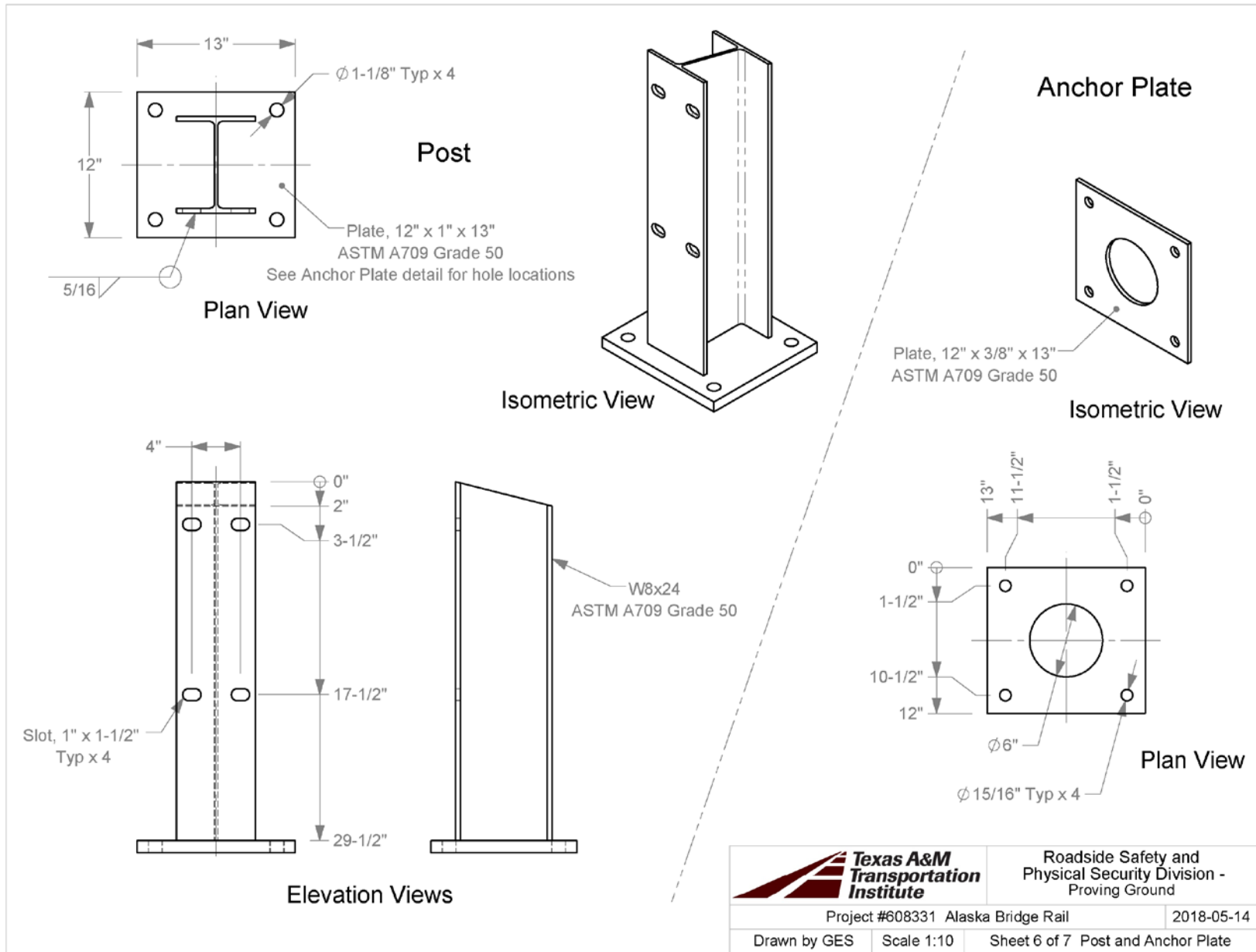


T:\1-ProjectFiles\608331- Alaska - Williams\Drafting, 608331 1-31608331 Drawing



5a. All bent bars, and all longitudinal bars in the Curb, Deck and Wall shall be epoxy coated. All bars are grade 60..

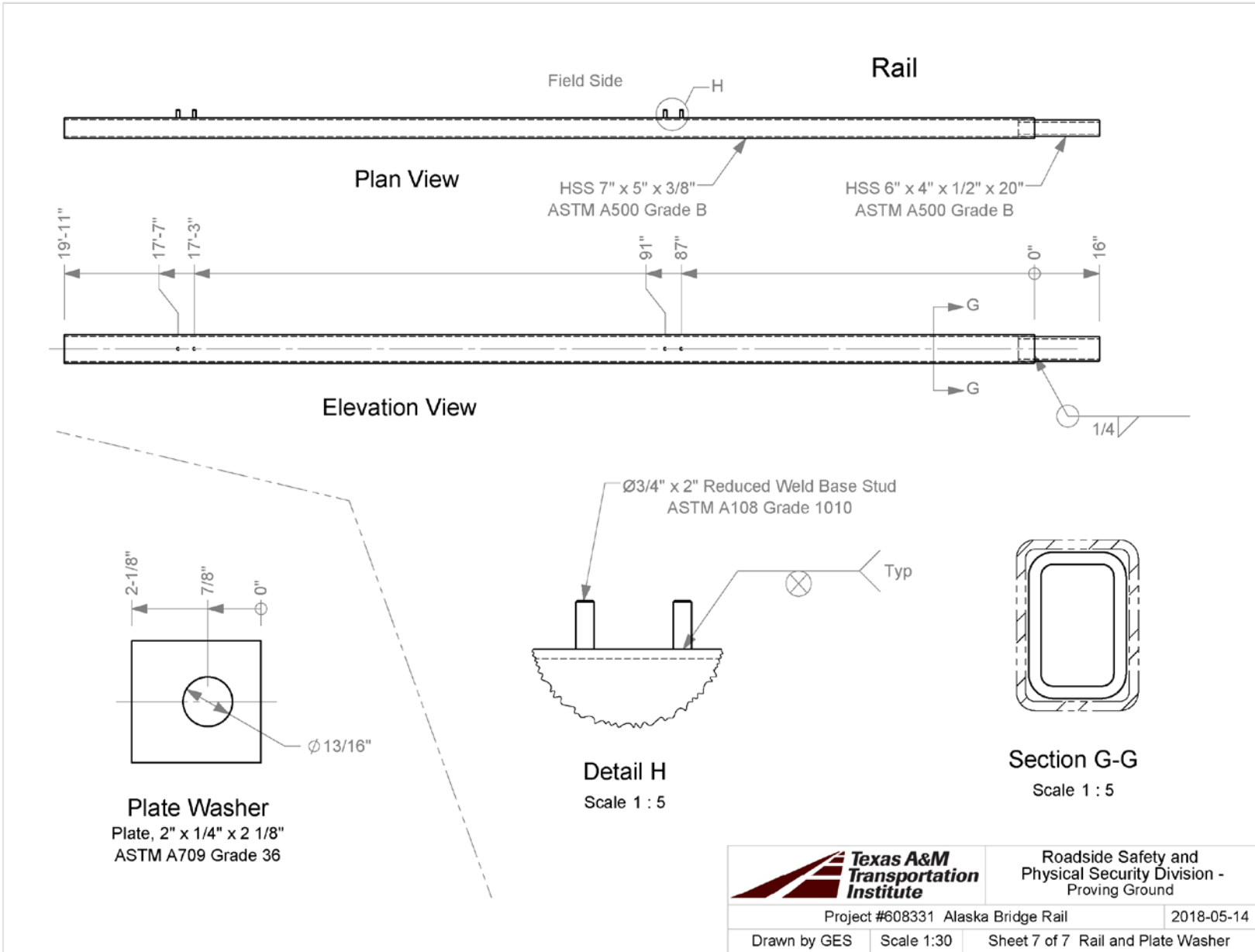
	Roadside Safety and Physical Security Division - Proving Ground	
	Project #608331 Alaska Bridge Rail	2018-05-14
Drawn by GES	Scale 1:10	Sheet 5 of 7 Rebar



Roadside Safety and Physical Security Division - Proving Ground

Project #608331 Alaska Bridge Rail		2018-05-14
Drawn by GES	Scale 1:10	Sheet 6 of 7 Post and Anchor Plate





T:\1-ProjectFiles\608331- Alaska - Williams\Drafting, 608331 1-31608331 Drawing

*This page intentionally left blank.*

# APPENDIX B. SUPPORTING CERTIFICATION DOCUMENTS



## CMC COATING TEXAS

P.O. BOX 2569  
 WAXAHACHIE, TX 75168-2569  
 (972)937-9841 FAX (972)937-3995

ELLIS-MCGINNIS CONSTRUCTION CO.  
 3100 STATE HWY 47, BLDG 7091  
 BRYAN, TX 77807

Sin#: 1823300820  
 Load: A  
 Project: TX A&M TRANSPORTATION  
 ALASKA "TEST" BRIDGE  
 Control: 608331  
 County: BRAZOS

Gentlemen:

This is to certify that all reinforcing steel for the above project has been coated in accordance with the TXDOT specifications item 440 and resin manufacturer's recommended specifications requirements.

Representative samples of the coated bars have been tested and the test results conform to the specification requirements.

We further certify Nap Gard 7-2719 or LILLY/VALSPAR 720A009, Scotchkote 413 Fusion Bonded Epoxy Powder from lot(s): 8496027182 was used to coat reinforcing steel from heats listed below.

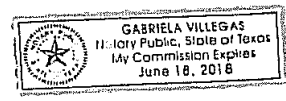
All bar is grade (420) 60 unless otherwise noted:

Bar Size		Weight		Heat #'s	Mill.... (other than CMC)
Metric	Imperial	Metric	Imperial		
(10)	3	0			
(13)	4	1,090	2,404	6001205	
(16)	5	1,585	3,494	3080435	
(19)	6	0			
(22)	7	0			
(25)	8	0			
(29)	9	0			
(32)	10	0			
(36)	11	0			
ttl. MG's:		2,675			
		ttl. LB's:	5,896		

The steel listed was manufactured by CMC Steel, unless otherwise stated above under Mill and shipped on Load A. We further certify that all manufacturing processes have occurred in the United States of America.

SUBSCRIBED AND SWORN TO BEFORE ME, a Notary Public in and for said County and State, on this the 28TH day of June, 2018.

*Gabriela Villegas*  
 Notary Public, Ellis Co., Texas  
 Gabriela Villegas



Contracted Manufacturer of ERICO Lenton Form Saver





CMC STEEL OKLAHOMA  
584 Old Highway 70  
Durant OK 74701-0000

**CERTIFIED MILL TEST REPORT**  
For additional copies call

We hereby certify that the test results presented here  
are accurate and conform to the reported grade specification

*Jacob Selzer*  
Jacob Selzer – CMC Steel

Quality Assurance Manager

HEAT NO.:6001205 SECTION: REBAR 13MM (#4) 60"0" 420/60 GRADE: ASTM A615-16 Gr 420/60 ROLL DATE: 06/13/2018 MELT DATE: 06/13/2018 Cert. No.: 82415724 / 001205J265	S O L D T O	CMC COATING WAXAHACHIE 901 CANTRELL STREET WAXAHACHIE TX US 75165-3120 972-937-9841	S H I P T O	CMC Coatings Waxahachie 901 Cantrell St Waxahachie TX US 75165-3120 972 937 9841	Delivery#: 82415724 BOL#: 72520380 CUST PO#: CUST P/N: DLVRY LBS / HEAT: 43204.000 LB DLVRY PCS / HEAT: 1078 EA
--	----------------------------	---	----------------------------	--	--

Characteristic	Value	Characteristic	Value	Characteristic	Value
C	0.26%	Bend Test Diameter	1.750IN	The Following is true of the material represented by this MTR: *Material is fully killed *100% melted and rolled in the USA *EN10204:2004 3.1 compliant *Contains no weld repair *Contains no Mercury contamination *Manufactured in accordance with the latest version of the plant quality manual *Meets the "Buy America" requirements of 23 CFR635 410	
Mn	0.97%	Bend Test 1	Passed		
P	0.011%	Rebar Deformation Avg. Spaci	0.336IN		
S	0.034%	Rebar Deformation Avg. Heigh	0.029IN		
Si	0.21%	Rebar Deformation Max. Gap	0.102IN		
Cu	0.26%	Uniform Elongation	8.1%		
Cr	0.12%				
Ni	0.11%				
Mo	0.029%				
V	0.005%				
Sn	0.009%				
Al	0.002%				
N	0.0121%				
Carbon Eq A6	0.48%				
Yield Strength test 1	125.1ksi				
Yield Strength test 1 (metric)	863MPa				
Tensile Strength test 1	141.0ksi				
Tensile Strength 1 (metric)	973MPa				
Elongation test 1	11%				
Elongation Gage Lgth test 1	8IN				

REMARKS :

TR No. 608331-1A-2-3

55

2019-04-02



CMC STEEL TEXAS  
1 STEEL MILL DRIVE  
SEGUIN TX 78155-7510

CERTIFIED MILL TEST REPORT  
For additional copies call  
830-372-8771

We hereby certify that the test results presented here  
are accurate and conform to the reported grade specification

*Tommy Hewitt*  
TOMMY HEWITT

Quality Assurance Manager

HEAT NO.:3080435 SECTION: REBAR 16MM (#5) 60'0" 420/60 GRADE: ASTM A615-16 Gr 420/60 ROLL DATE: 05/26/2018 MELT DATE: 05/24/2018 Cert. No.: 82415821 / 080435A002	S O L D T O	CMC COATING WAXAHACHIE  901 CANTRELL STREET WAXAHACHIE TX US 75165-3120 972-937-9841	S H I P T O	CMC Coatings Waxahachie  901 Cantrell St Waxahachie TX US 75165-3120 972 937 9841	Delivery#: 82415821 BOL#: 72520539 CUST PO#: CUST P/N: DLVRY LBS / HEAT: 45060.000 LB DLVRY PCS / HEAT: 720 EA
--	----------------------------	---	----------------------------	--	---

Characteristic	Value	Characteristic	Value	Characteristic	Value
C	0.42%				
Mn	0.75%				
P	0.012%				
S	0.053%				
Si	0.18%				
Cu	0.31%				
Cr	0.16%				
Ni	0.17%				
Mo	0.079%				
V	0.000%				
Cb	0.001%				
Sn	0.012%				
Al	0.002%				
Yield Strength test 1	67.9ksi				
Tensile Strength test 1	103.4ksi				
Elongation test 1	16%				
Elongation Gage Lgth test 1	8IN				
Bend Test Diameter	2.188IN				
Bend Test 1	Passed				
<p>The Following is true of the material represented by this MTR:</p> <ul style="list-style-type: none"> <li>*Material is fully killed</li> <li>*100% melted and rolled in the USA</li> <li>*EN10204:2004 3.1 compliant</li> <li>*Contains no weld repair</li> <li>*Contains no Mercury contamination</li> <li>*Manufactured in accordance with the latest version of the plant quality manual</li> <li>*Meets the "Buy America" requirements of 23 CFR635 410</li> </ul>					

EMARKS :



# Valspar Corporation

## CERTIFICATION of COMPLIANCE

Date: 5/9/2018

Specification: ASTM A775, ASTM A1078, AASHTO M284, AASHTO M254

Valspar Product Code: 720A009 (Epoxy Powder for Coating)

Batch Number: 8496027182

Production Date: 5/8/2018 (Expiration is 6 months post production date)

Batch Size: 19,800 lbs.

I hereby certify that the above lot of material was manufactured to formulation, meeting all the requirements of the above specifications and that this material is chemically the same material that was tested by Valley Forge Laboratories of Devon, PA. or Wiss, Janney, Elstner Associates of Northbrook, IL.

The individual signing below has the legal authority to bind Valspar to the material.

Eric Gregory / QA Supervisor  
Name and Title  
Eric Gregory  
Signature  
5/9/18  
Date

10300 Claude Freeman Drive  
Charlotte, NC 28262  
Phone: (704) 548-2820  
Fax: (704) 547-0634

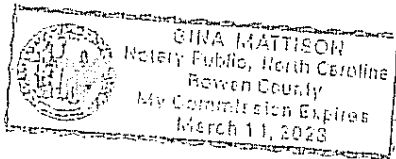
State/County: NC / Mecklenburg  
On this the 9 Day of May, 2018, before me Gina Mattison  
Name of Notary Public  
The undersigned Notary Public, personally appeared Eric Gregory  personally known to me  
Name(s) of Signer(s)

To be the person(s) whose name(s) is/are subscribed to the within instrument, and I acknowledged to me that he/she/they executed the same for the purposes therein stated.

Witness my hand and official seal


Gina Mattison  
Signature of Notary Public

Gina Mattison - Rowan  
Other Required Information (Printed Name of Notary, Residence, etc.)



The material identified above were produced in the United States and qualify as "U.S.-made end products", "domestic construction materials" and "domestic manufactured goods."

The data on this sheet represent measured values. Given application variables are a major factor in product performance, this information should serve only as a general guide. Valspar assumes no obligation or liability for use of this information. UNLESS VALSPAR AGREES OTHERWISE IN WRITING, VALSPAR MAKES NO WARRANTIES, EXPRESS OR IMPLIED, AND DISCLAIMS ALL IMPLIED WARRANTIES INCLUDING WARRANTIES OF MERCHANTABILITY OR FITNESS FOR A PARTICULAR USE OR FREEDOM FROM PATENT INFRINGEMENT. VALSPAR WILL NOT BE LIABLE FOR ANY SPECIAL, INCIDENTAL OR CONSEQUENTIAL DAMAGES. Your only remedy for any defect in this product is the replacement of the defective product, or a refund of its purchase price, at our option.

	<b>CMC Epoxy Coatings</b> <b>Quality Control</b>	901 Cantrell Street
		Waxahatchie, TX 75165 972-937-9841

Workbook ID: 20180620D1  
 Production Date: Wednesday, June 20, 2018  
 InspectorName: Jose Bedolla  
 Shift day: Times 4:00 AM 4:00 PM

**General Daily Information**

Lines Running	Line1	Line2	Line3	Line4	Heat Numbers		Comments
					Line	Heat Number	
1-4 Operator	Hector		PowderLot	8496027182	1-4	6000949	
Bar Size 1-4	5		Expiration	11/8/2018	1-4	6000950	
Lines Running	Line5	Line6	Line7	Line8	1-4	6000951	
5-8 Operator	Enrique		PowderLot	8496027182	1-4	6000948	
Bar Size 5-8	4		Expiration	11/8/2018	5-8	6001205	
Alternate Powder Lot	Alternate Powder Expiration						

Contaminants	T2.1.3.2 Uncoated bars free of oils, greases, paints and salts.										Comments	
# Bundles Checked	2	Bundles OK?	<input checked="" type="checkbox"/>	Qty of Noted Bars	0	Noted <1%	0	Noted >1%	0	Time	4:25	Contaminants, Surface Defects and treatment:
	1		<input checked="" type="checkbox"/>		0		0		0		1:05	

Surface Defects	T2.1.3.1 Uncoated bars free of excessive slivers or detrimental defects.										
# Bundles Checked	2	Bundles OK?	<input checked="" type="checkbox"/>	Qty of Noted Bars	0	Noted <1%	0	Noted >1%	0	Time	4:25
	1		<input checked="" type="checkbox"/>		0		0		0		1:05

	Line 1	Line 2	Line 3	Line 4	Line 5	Line 6	Line 7	Line 8	
Grit Blast Equip:OK?	<input checked="" type="checkbox"/>	<input checked="" type="checkbox"/>	<input checked="" type="checkbox"/>	<input checked="" type="checkbox"/>	<input checked="" type="checkbox"/>	<input checked="" type="checkbox"/>	<input checked="" type="checkbox"/>	<input checked="" type="checkbox"/>	T3.3.3.1 Grit Blasting Machine, proper equipment operation.
Bar Transport Sys.?	<input checked="" type="checkbox"/>	<input checked="" type="checkbox"/>	<input checked="" type="checkbox"/>	<input checked="" type="checkbox"/>	<input checked="" type="checkbox"/>	<input checked="" type="checkbox"/>	<input checked="" type="checkbox"/>	<input checked="" type="checkbox"/>	T7.1.3.1 Inspect Bar Transport System

Chart Recorder Temp	67°	T5.1.3.2 Powder Storage Area. The 7-day temperature recorder charts are kept in our QC files each week. Temperature per manufacturer specifications.	PreShipInspection	4:10	T11.1.3.2 Inspect Coated Rebar Prior To Shipment for coating fractures, tears, non-painted, or uncoated areas.
Compressor Temp	171°		StockInspection	4:20	T11.2.3.1 Inspect Stockpiles of Coated Bars Stored in Floor Stock for uncoated areas, greases, excessive damage, etc.
AlarmSystem <input checked="" type="checkbox"/>	Checked for Dry Air <input checked="" type="checkbox"/>		Water Discharge <input checked="" type="checkbox"/>	Thickness Gauge Calibration	4:05

**Bar Coating Times**

Line	Test Time	Length	Motor Speed	Blast to Coat	G I	Quench	Ln Rate	i Spi
1-4	5:15	60	42 Hz	00:35	:07	00:33	02:02	30 Ft
5-8	5:25	60	39 Hz	00:50	:09	00:40	02:20	26 Ft
1-4	1:05	60	42 Hz	00:35	:07	00:33	02:02	30 Ft

**Bar Temperatures**

Line	Hi Temp	Lo Temp	IR Temp	Time A	IR Temp	Time B	IR Temp	Time C
1	450°	425°	421°	5:25	418°	1:10	"	"
2	450°	425°	420°	5:25	421°	1:10	"	"
3	450°	425°	423°	5:25	417°	1:10	"	"
4	450°	425°	420°	5:25	420°	1:10	"	"
5	450°	425°	418°	5:35	"	"	"	"
6	450°	425°	420°	5:35	"	"	"	"
7	450°	425°	421°	5:35	"	"	"	"
8	450°	425°	419°	5:35	"	"	"	"

T7.1.3.2 Gel Time: 7s (min), powder cloud to 1st roller.  
 T7.2.3.2 Quench Time: 28s min, powder cloud to water quench.

T4.1.3.1 3M Infrared Thermometer (IR16), set at .48 emissivity on black bar and averages 449°F. Crayons Melt at 449°F.

**PSI, KV, Application**

Line	Time A	Test A			Time B	Test B			Abrasive Contamination		Holiday Detectors		IL Count Holiday	HH Count	Time
		Pressure A	Electro-static A	Spray Applic		Pressure B	Electro-static	Spray Applic	Abrasive: Oil	Abrasive:	In Line Detecto	Counters In-Line			
1	5:40	99 psi	100 kV	<input checked="" type="checkbox"/>	1:15	99 psi	100 kV	<input checked="" type="checkbox"/>	<input checked="" type="checkbox"/>	<input checked="" type="checkbox"/>	<input checked="" type="checkbox"/>	<input checked="" type="checkbox"/>	1	1	6:15
2	5:40	99 psi	98 kV	<input checked="" type="checkbox"/>	1:15	99 psi	98 kV	<input checked="" type="checkbox"/>	<input checked="" type="checkbox"/>	<input checked="" type="checkbox"/>	<input checked="" type="checkbox"/>	<input checked="" type="checkbox"/>	1	0	6:15
3	5:40	99 psi	98 kV	<input checked="" type="checkbox"/>	1:15	99 psi	98 kV	<input checked="" type="checkbox"/>	<input checked="" type="checkbox"/>	<input checked="" type="checkbox"/>	<input checked="" type="checkbox"/>	<input checked="" type="checkbox"/>	1	1	6:15
4	5:40	97 psi	94 kV	<input checked="" type="checkbox"/>	1:15	99 psi	96 kV	<input checked="" type="checkbox"/>	<input checked="" type="checkbox"/>	<input checked="" type="checkbox"/>	<input checked="" type="checkbox"/>	<input checked="" type="checkbox"/>	1	1	6:15
5	5:40	80 psi	70 kV	<input checked="" type="checkbox"/>		psi	kV	<input type="checkbox"/>	<input checked="" type="checkbox"/>	<input checked="" type="checkbox"/>	<input checked="" type="checkbox"/>	<input checked="" type="checkbox"/>	1	1	6:25
6	5:40	75 psi	70 kV	<input checked="" type="checkbox"/>		psi	kV	<input type="checkbox"/>	<input checked="" type="checkbox"/>	<input checked="" type="checkbox"/>	<input checked="" type="checkbox"/>	<input checked="" type="checkbox"/>	1	1	6:25
7	5:40	20 psi	70 kV	<input checked="" type="checkbox"/>		psi	kV	<input type="checkbox"/>	<input checked="" type="checkbox"/>	<input checked="" type="checkbox"/>	<input checked="" type="checkbox"/>	<input checked="" type="checkbox"/>	1	1	6:25
8	5:40	15 psi	99 kV	<input checked="" type="checkbox"/>		psi	kV	<input type="checkbox"/>	<input checked="" type="checkbox"/>	<input checked="" type="checkbox"/>	<input checked="" type="checkbox"/>	<input checked="" type="checkbox"/>	1	1	6:25

T6.1.3.1 Powder Air Supply (Desiccant)  
 T6.2.3.1 Spray Application/Electrostatic System  
 T3.3.3.2 Oil Contamination in Abrasives. T3.3.3.2 Chlorides in Abrasives.  
 T8.1.1, T8.1.3.1 In-Line Holiday Detectors and Counters Functioning Properly.  
 T8.1.3.2 Continuity of Coating. Comparison verification of holiday detectors.

**Bend Test**

Line	Angle	Pin Dia	A- Time	A- Bar Temp	A- Bend Seconds	A- Passed	A- Retest?	A- Passed Retest?	B- Time	B- Bar Temp	B- Bend Seconds	B- Passed	B- Retest?	B- Passed Retest?	C- Time	C- Bar Temp	C- Bend Seconds	C- Passed	C- Retest?	C Passed Retest?
1	180	3.5	5:15	74	3	<input checked="" type="checkbox"/>	<input type="checkbox"/>	<input type="checkbox"/>	9:15	75	3	<input checked="" type="checkbox"/>	<input type="checkbox"/>	<input type="checkbox"/>	1:05	79	3	<input checked="" type="checkbox"/>	<input type="checkbox"/>	<input type="checkbox"/>
2	180	3.5	5:15	74	3	<input checked="" type="checkbox"/>	<input type="checkbox"/>	<input type="checkbox"/>	9:15	75	3	<input checked="" type="checkbox"/>	<input type="checkbox"/>	<input type="checkbox"/>	1:05	79	3	<input checked="" type="checkbox"/>	<input type="checkbox"/>	<input type="checkbox"/>
3	180	3.5	5:15	74	3	<input checked="" type="checkbox"/>	<input type="checkbox"/>	<input type="checkbox"/>	9:15	75	3	<input checked="" type="checkbox"/>	<input type="checkbox"/>	<input type="checkbox"/>	1:05	79	3	<input checked="" type="checkbox"/>	<input type="checkbox"/>	<input type="checkbox"/>
4	180	3.5	5:15	74	3	<input checked="" type="checkbox"/>	<input type="checkbox"/>	<input type="checkbox"/>	9:15	75	3	<input checked="" type="checkbox"/>	<input type="checkbox"/>	<input type="checkbox"/>	1:05	79	3	<input checked="" type="checkbox"/>	<input type="checkbox"/>	<input type="checkbox"/>
5	180	3	5:15	75	3	<input checked="" type="checkbox"/>	<input type="checkbox"/>	<input type="checkbox"/>	9:15	80	3	<input checked="" type="checkbox"/>	<input type="checkbox"/>	<input type="checkbox"/>		70	3	<input type="checkbox"/>	<input type="checkbox"/>	<input type="checkbox"/>
6	180	3	5:15	75	3	<input checked="" type="checkbox"/>	<input type="checkbox"/>	<input type="checkbox"/>	9:15	80	3	<input checked="" type="checkbox"/>	<input type="checkbox"/>	<input type="checkbox"/>		70	3	<input type="checkbox"/>	<input type="checkbox"/>	<input type="checkbox"/>
7	180	3	5:15	75	3	<input checked="" type="checkbox"/>	<input type="checkbox"/>	<input type="checkbox"/>	9:15	80	3	<input checked="" type="checkbox"/>	<input type="checkbox"/>	<input type="checkbox"/>		70	3	<input type="checkbox"/>	<input type="checkbox"/>	<input type="checkbox"/>
8	180	3	5:15	75	3	<input checked="" type="checkbox"/>	<input type="checkbox"/>	<input type="checkbox"/>	9:15	80	3	<input checked="" type="checkbox"/>	<input type="checkbox"/>	<input type="checkbox"/>		70	3	<input type="checkbox"/>	<input type="checkbox"/>	<input type="checkbox"/>

T10.1.3.2 Bend Test. Bar temperature less than 86°F. Perform a Bend Test on ALL Heat Numbers.

**Bar Tests- CS, BC, Chloride subform**

Line	Time		Backside Contamination				Profile Appearance				Color Appearance			
	T1	T2	T1	T2	T3	T4	T1	T2	T3	T4	T1	T2	T3	T4
1	7:00	11:00	10%	12%	0%	0%	5.5	5.5	5.5	5.5	A SP 10	A SP 10	A SP 10	A SP 10
4	7:00	11:00	12%	10%	0%	0%	5.5	5.5	5.5	5.5	A SP 10	A SP 10	A SP 10	A SP 10
3	7:00	11:00	10%	10%	0%	0%	5.5	5.5	5.5	5.5	A SP 10	A SP 10	A SP 10	A SP 10
2	7:00	11:00	10%	10%	0%	0%	5.5	5.5	5.5	5.5	A SP 10	A SP 10	A SP 10	A SP 10
8	6:30	10:30	13%	10%	0%	0%	5.5	5.5	5.5	5.5	A SP 10	A SP 10	A SP 10	A SP 10
5	6:30	10:30	10%	10%	0%	0%	5.5	5.5	5.5	5.5	A SP 10	A SP 10	A SP 10	A SP 10
6	6:30	10:30	12%	10%	0%	0%	5.5	5.5	5.5	5.5	A SP 10	A SP 10	A SP 10	A SP 10
7	6:30	10:30	13%	10%	0%	0%	5.5	5.5	5.5	5.5	A SP 10	A SP 10	A SP 10	A SP 10
4			0%	0%	0%	0%	5.5	5.5	5.5	5.5	A SP 10	A SP 10	A SP 10	A SP 10
3			0%	0%	0%	0%	5.5	5.5	5.5	5.5	A SP 10	A SP 10	A SP 10	A SP 10
2			0%	0%	0%	0%	5.5	5.5	5.5	5.5	A SP 10	A SP 10	A SP 10	A SP 10
8			0%	0%	0%	0%	5.5	5.5	5.5	5.5	A SP 10	A SP 10	A SP 10	A SP 10
5			0%	0%	0%	0%	5.5	5.5	5.5	5.5	A SP 10	A SP 10	A SP 10	A SP 10
6			0%	0%	0%	0%	5.5	5.5	5.5	5.5	A SP 10	A SP 10	A SP 10	A SP 10
7			0%	0%	0%	0%	5.5	5.5	5.5	5.5	A SP 10	A SP 10	A SP 10	A SP 10
1			0%	0%	0%	0%	5.5	5.5	5.5	5.5	A SP 10	A SP 10	A SP 10	A SP 10

	<b>CMC Epoxy Coatings Quality Control</b>	901 Cantrell Street
		Waxahachie, TX 75165 972-937-9841

Workbook ID: 20180615D1      InspectorName: Josue Justiniano  
 Production Date: Friday, June 15, 2018      Shift Day: Times 4:00 AM 4:00 PM

General Daily Information				Heat Numbers		Comments
Lines Running	Line1 <input type="radio"/>	Line2 <input type="radio"/>	Line3 <input type="radio"/>	Line4 <input type="radio"/>	Line	Heat Number
1-4 Operator	PowderLot			5-8	3080435	
Bar Size 1-4	Expiration			5-8	3078306	
Lines Running	Line5 <input checked="" type="radio"/>	Line6 <input type="radio"/>	Line7 <input type="radio"/>	Line8 <input checked="" type="radio"/>		
5-8 Operator	Enrique		PowderLot	8496027182		
Bar Size 5-8	5		Expiration	11/8/2018		
Alternate Powder Lot			Alternate Powder Expiration			

Contaminants	T2.1.3.2 Uncoated bars free of oils, greases, paints and salts.								Comments			
# Bundles Checked	1	Bundles OK?	<input checked="" type="checkbox"/>	Qty of Noted Bars	0	Noted <1%	0	Noted >1%	0	Time	4:05	
	2		<input checked="" type="checkbox"/>		0		0		0		1:00	
Surface Defects	T2.1.3.1 Uncoated bars free of excessive slivers or detrimental defects.								T3.3.3.1 Grit Blasting Machine, proper equipment operation. T7.1.3.1 Inspect Bar Transport System			
# Bundles Checked	1	Bundles OK?	<input checked="" type="checkbox"/>	Qty of Noted Bars	0	Noted <1%	0	Noted >1%		0	Time	4:05
	2		<input checked="" type="checkbox"/>		0		0			0		1:00
Grit Blast Equip:OK?	Line 1	Line 2	Line 3	Line 4	Line 5	Line 6	Line 7	Line 8				
	<input type="checkbox"/>	<input type="checkbox"/>	<input type="checkbox"/>	<input type="checkbox"/>	<input checked="" type="checkbox"/>	<input checked="" type="checkbox"/>	<input checked="" type="checkbox"/>	<input checked="" type="checkbox"/>				
Bar Transport Sys.?	<input type="checkbox"/>	<input type="checkbox"/>	<input type="checkbox"/>	<input type="checkbox"/>	<input checked="" type="checkbox"/>	<input checked="" type="checkbox"/>	<input checked="" type="checkbox"/>	<input checked="" type="checkbox"/>				
Chart Recorder Temp	68°	T5.1.3.2 Powder Storage Area. The 7-day temperature recorder charts are kept in our QC files each week. Temperature per manufacturer specifications.			PreShipInspection	4:30	T11.1.3.2 Inspect Coated Rebar Prior To Shipment for coating fractures, tears, non-painted, or uncoated areas.					
Compressor Temp	171°				StockInspection	4:40	T11.2.3.1 Inspect Stockpiles of Coated Bars Stored in Floor Stock for uncoated areas, greases, excessive damage, etc.					
AlarmSystem <input checked="" type="checkbox"/>	Checked for Dry Air <input checked="" type="checkbox"/>	Water Discharge <input checked="" type="checkbox"/>			Thickness Gauge Calibration	4:00	T9.1.3.2 Calibrated Coating Thickness Gauge at 7.35 mils SRM 1362A.					



**Bar Coating Times**

Line	Test Time	Length	Motor Speed	Blast to Coat	Gel	Quench	In Rate	Temp
5-8	4:05	60	38 Hz	00:49	:08	00:39	02:19	26 Fj
5-8	1:05	60	38 Hz	00:49	:08	00:39	02:19	26 Fj

**Bar Temperatures**

Line	Hi Temp	Lo Temp	IR Temp	Time A	IR Temp	Time B	IR Temp	Time C
5	463°	450°	419°	4:10	420°	1:10	"	"
6	463°	450°	416°	4:10	418°	1:10	"	"
7	463°	450°	421°	4:10	422°	1:10	"	"
8	463°	450°	420°	4:10	420°	1:10	"	"

T7.1.3.2 Gel Time: 7s (min), powder cloud to 1st roller.  
 T7.2.3.2 Quench Time: 28s min, powder cloud to water quench.

T4.1.3.1 3M Infrared Thermometer (IR16), set at .48 emissivity on black bar and averages 449°F. Crayons Melt at 449°F.

**PSI, KVs, Application**

Line	Test A				Test B				Abrasive Contamination		Holiday Detectors		IL Count Holiday	HH Count	Time
	Time A	Pressure A	Electro-static A	Spray Applic	Time B	Pressure B	Electro-static B	Spray Applic	Abrasive Oil	Abrasive:	In Line Detecto	Counters In-Line			
5	4:15	85 psi	79 kV	<input checked="" type="checkbox"/>	1:15	85 psi	79 kV	<input checked="" type="checkbox"/>	<input checked="" type="checkbox"/>	<input checked="" type="checkbox"/>	<input checked="" type="checkbox"/>	<input checked="" type="checkbox"/>	2	1	6:10
6	4:15	80 psi	70 kV	<input checked="" type="checkbox"/>	1:15	80 psi	70 kV	<input checked="" type="checkbox"/>	<input checked="" type="checkbox"/>	<input checked="" type="checkbox"/>	<input checked="" type="checkbox"/>	<input checked="" type="checkbox"/>	1	1	6:10
7	4:15	10 psi	80 kV	<input checked="" type="checkbox"/>	1:15	10 psi	80 kV	<input checked="" type="checkbox"/>	<input checked="" type="checkbox"/>	<input checked="" type="checkbox"/>	<input checked="" type="checkbox"/>	<input checked="" type="checkbox"/>	1	0	6:10
8	4:15	psi	99 kV	<input checked="" type="checkbox"/>	1:15	psi	99 kV	<input checked="" type="checkbox"/>	<input checked="" type="checkbox"/>	<input checked="" type="checkbox"/>	<input checked="" type="checkbox"/>	<input checked="" type="checkbox"/>	1	1	6:10

T6.1.3.1 Powder Air Supply (Desiccant)  
 T6.2.3.1 Spray Application/Electrostatic System  
 T3.3.3.2 Oil Contamination in Abrasives. T3.3.3.2 Chlorides in Abrasives.  
 T8.1.1, T8.1.3.1 In-Line Holiday Detectors and Counters Functioning Properly.  
 T8.1.3.2 Continuity of Coating. Comparison verification of holiday detectors.

**Bend Test**

Line	Angle	Pin Dia	A-Time	A-Bar Temp	A-Bend Seconds	A-Passed	A-Retest?	A-Passed Retest?	B-Time	B-Bar Temp	B-Bend Seconds	B-Passed	B-Retest?	B-Passed Retest?	C-Time	C-Bar Temp	C-Bend Seconds	C-Passed	C-Retest?	C-Passed Retest?
5	180	3.5	5:20	76	3	<input checked="" type="checkbox"/>	<input type="checkbox"/>	<input type="checkbox"/>	9:00	75	3	<input checked="" type="checkbox"/>	<input type="checkbox"/>	<input type="checkbox"/>	1:00	76	3	<input checked="" type="checkbox"/>	<input type="checkbox"/>	<input type="checkbox"/>
6	180	3.5	5:20	76	3	<input checked="" type="checkbox"/>	<input type="checkbox"/>	<input type="checkbox"/>	9:00	75	3	<input checked="" type="checkbox"/>	<input type="checkbox"/>	<input type="checkbox"/>	1:00	76	3	<input checked="" type="checkbox"/>	<input type="checkbox"/>	<input type="checkbox"/>
7	180	3.5	5:20	76	3	<input checked="" type="checkbox"/>	<input type="checkbox"/>	<input type="checkbox"/>	9:00	75	3	<input checked="" type="checkbox"/>	<input type="checkbox"/>	<input type="checkbox"/>	1:00	76	3	<input checked="" type="checkbox"/>	<input type="checkbox"/>	<input type="checkbox"/>
8	180	3.5	5:20	76	3	<input checked="" type="checkbox"/>	<input type="checkbox"/>	<input type="checkbox"/>	9:00	75	3	<input checked="" type="checkbox"/>	<input type="checkbox"/>	<input type="checkbox"/>	1:00	76	3	<input checked="" type="checkbox"/>	<input type="checkbox"/>	<input type="checkbox"/>

T10.1.3.2 Bend Test. Bar temperature less than 86°F. Perform a Bend Test on ALL Heat Numbers.

**Bar Tests- CS, BC, Chloride subform**

Line	Time		T1	T2	Backside Contamination				Profile Appearance				Color Appearance			
	T1	T2			T1	T2	T3	T4	T	T2	T3	T4	T1	T2	T3	T4
1	7:00	11:00			10%	12%	0%	0%	5.5	5.5	5.5	5.5	A SP 10	A SP 10	A SP 10	A SP 10
4	7:00	11:00			12%	10%	0%	0%	5.5	5.5	5.5	5.5	A SP 10	A SP 10	A SP 10	A SP 10
3	7:00	11:00			10%	10%	0%	0%	5.5	5.5	5.5	5.5	A SP 10	A SP 10	A SP 10	A SP 10
2	7:00	11:00			10%	10%	0%	0%	5.5	5.5	5.5	5.5	A SP 10	A SP 10	A SP 10	A SP 10
8	6:30	10:30			13%	10%	0%	0%	5.5	5.5	5.5	5.5	A SP 10	A SP 10	A SP 10	A SP 10
5	6:30	10:30			10%	10%	0%	0%	5.5	5.5	5.5	5.5	A SP 10	A SP 10	A SP 10	A SP 10
6	6:30	10:30			12%	10%	0%	0%	5.5	5.5	5.5	5.5	A SP 10	A SP 10	A SP 10	A SP 10
7	6:30	10:30			13%	10%	0%	0%	5.5	5.5	5.5	5.5	A SP 10	A SP 10	A SP 10	A SP 10
4					0%	0%	0%	0%	5.5	5.5	5.5	5.5	A SP 10	A SP 10	A SP 10	A SP 10
3					0%	0%	0%	0%	5.5	5.5	5.5	5.5	A SP 10	A SP 10	A SP 10	A SP 10
2					0%	0%	0%	0%	5.5	5.5	5.5	5.5	A SP 10	A SP 10	A SP 10	A SP 10
8					0%	0%	0%	0%	5.5	5.5	5.5	5.5	A SP 10	A SP 10	A SP 10	A SP 10
5					0%	0%	0%	0%	5.5	5.5	5.5	5.5	A SP 10	A SP 10	A SP 10	A SP 10
6					0%	0%	0%	0%	5.5	5.5	5.5	5.5	A SP 10	A SP 10	A SP 10	A SP 10
7					0%	0%	0%	0%	5.5	5.5	5.5	5.5	A SP 10	A SP 10	A SP 10	A SP 10
1					0%	0%	0%	0%	5.5	5.5	5.5	5.5	A SP 10	A SP 10	A SP 10	A SP 10

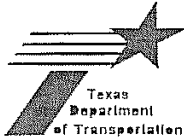
T3. I.3.2 Backside Contamination, use 3M-471 tape and visual.  
 T3. I.4.2 Blast Cleaning, use surface comparator and SSPC-VIS 1-89

**Bar Tests- Copper Sulfate and Chloride**

ProfileReadings

T3. I.3.2 Copper Sulfate, use visual standard.  
 T3. I.3.2 Chloride Test, use Chloride test strips.

T3.2.3.2 Perthometer: RMax/Peak/S-Factor



**MATERIAL STATEMENT**

SUPPLIER: Texas Corrugators-Austin Division, Inc.  
 ADDRESS: 105 Tradesman Park Dr.  
 Hutto, TX 78634  
 CONTRACT NUMBER: 512-388-0588

COUNTY:  
 PROJECT: TTI ALASKA RAIL  
 CONTROL:  
 CONTRACTOR: ELLIS-MCGINNIS CONSTRUCTION

Purchase Order #	Quantity (Amt/Units)	MATERIAL DESCRIPTION	Mill Name	Heat #	Material Use	Required Specification	Documentation HTR	Cert
J-1097	40 L. F.	W8 X 24# BEAM	NUCOR	487304	GALVANIZED STEEL RAIL.	A709-50	X	
	17.2 SQ. FT.	1" PLATE	ARCELORMITTA L BURNS	174P79150		A709-50	X	
	17.2 SQ. FT.	3/8" PLATE	NUCOR	B8P3406	GALVANIZED STEEL RAIL.	A709-50	X	
	23.3 L. F.	6" X 4" X 1/2" RECT. TUBE	SOUTHLAND TUBE	2801948		A500-13 B/C	X	
	308.8 L. F.	5" X 7" X 3/8" RECT. TUBE	INDEPENDENCE TUBE	C86773	GALVANIZED STEEL RAIL.	A500 B/C	X	
	10.56 L. F.	1/4" X 2" FLAT	NUCOR	JW1810748 0		A36/A529-50	X	

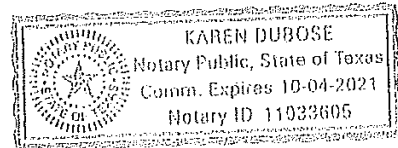
This is to certify that the materials listed above and on the attached supplement (if attached) are in conformance with the governing specification(s). This is also to certify that all manufacturing processes for steel and iron materials or for the application of coatings (epoxy, galvanizing, painting or any other coating that protects or enhances the value of the steel or iron material) to these materials occurred in the United States of America. Manufacturing processes are defined as all processes required to change the raw ore or scrap metal into the finished in-place steel or iron product. The attached mill test reports (MTRs) and Certifications (Cert.) are offered as proof of domestic origin.

Subscribed and sworn to before me

this 12<sup>th</sup> day of Sept 20 18

Notary Public *Karen Dubose*

My Commission Expires: 10.4 20 21



I declare under penalty of perjury under the laws of the United States of America and the State of Texas, that the foregoing is true and correct and that I am authorized to sign for the firm listed above.

*[Signature]* 9/12/18  
 Authorized Corporate Official Signature Date

Ryan J. Cole – Vice President

Type Name and Title

Texas Corrugators-Austin Division, Inc.

(Firm Name)



ArcelorMittal Burns Harbor Plate

US HWY 12 Burns Harbor, Indiana

QUALITY ASSURANCE  
REPORT OF TEST AND ANALYSES

SHIPMENT NO. 8GA-10412	DATE SHIPPED 02-28-18	CAR OR VEHICLE NO. CUSTOMER TRUCK	T	HAMM
---------------------------	--------------------------	--------------------------------------	---	------

S	E	R	I	O	N	SIZE AND QUANTITY				YIELD POINT	TENSILE STRENGTH	AF FRAC. ELONG.	RED.
						THICKNESS	WIDTH OR DIA.	LENGTH	WEIGHT				

QUALITY STEEL MELTED & MANUFACTURED IN THE U. S. A.  
 PLATES - AASHTO M270-15 GR 50 KLD FINE GRAIN  
 PRAC NO IMPACTS REQUIRED TYPE 2,  
 ASTM A709-13A GR 50, ASTM A572-06  
 GR 50, ASME SA572 GR 50 2013  
 EDITION  
 MFST - MFST MILL SERIAL# & PATTERN# MFST PROC ON  
 GH820-1183A LIFT MAX 15 TON-SIZES & GRADES SEP  
 UNLDG FORK LIFT-SIDE FOR ULTIMATE DELIVERY  
 LAYER

5 / 10 / 2018 SFI-GRAY STEEL  
 Customer Name:  
 Customer PO #:  
 Thickness: 1" SFI PG #: 702271  
 Heat & Slab: 174P79150  
 Plate #: 55690-3

CO#	HEAT NUMBER	PAT NO.	HEAT NUMBER	NO. PCS.	THICKNESS	WIDTH OR DIA.	LENGTH	WEIGHT	YIELD POINT	TENSILE STRENGTH	AF FRAC. ELONG.	RED.
23.579	174P79150	1	1	1	96	240	240	6534	52600	84000	8	25
H54842801	174P79150	1	1	1	96	240	240	6534	52600	84000	8	25
H54842802	174P79150	1	1	1	96	240	240	6534	52600	84000	8	25
H54842803	174P79150	1	1	1	96	240	240	6534	52600	84000	8	25

Q-QUENCH TEMPERATURE	T-TEMPERATURE	N-NORMALIZE TEMPERATURE
----------------------	---------------	-------------------------

S	E	R	I	O	N	HARD BHN	BEND	THICKNESS INCHES	TYPE	SIZE	DIR	TEST TEMP F	CHARPY IMPACT					
													ENERGY FT LBS			SHEAR (%)		

HEAT NUMBER	CHEMICAL ANALYSIS														MQLAID GRAIN SIZE	
	C	Mn	P	S	Si	Cu	Ni	Cr	Mo	V	Ti	Al	B	Co		N
174P79150	.18	1.23	.015	.003	.295	.025	.02	.03	.006	.056	.003	.028	.0003	.002	.005	.002

I certify that the above results are a true and correct copy of actual results maintained in records maintained by ArcelorMittal Burns Harbor and are in full compliance with the requirements of the specification cited above. This test report cannot be altered and must be transmitted intact with any subsequent third party test reports, if required.

ANDREW SMITH PER ELJ

SFI GRAY STEEL - Date: 8/2/2018 - Customer: TEXAS CORRUGATORS - ALU. IN DIV. (EMAIL INV.) - PO# J-1097-1 - P/N:





CMC STEEL TEXAS  
1 STEEL MILL DRIVE  
SEGUIN TX 78155-7510

**CERTIFIED MILL TEST REPORT**  
For additional copies call  
830-372-8771

We hereby certify that the test results presented here  
are accurate and conform to the reported grade specification

*Tommy Hewitt*  
TOMMY HEWITT

Quality Assurance Manager

HEAT NO.:3080435 SECTION: REBAR 16MM (#5) 60"0" 420/60 GRADE: ASTM A615-16 Gr 420/60 ROLL DATE: 05/26/2018 MELT DATE: 05/24/2018 Cert. No.: 82415821 / 080435A002	S O L D T O	CMC COATING WAXAHACHIE  901 CANTRELL STREET WAXAHACHIE TX US 75165-3120 972-937-9841	S H I P T O	CMC Coatings Waxahachie  901 Cantrell St Waxahachie TX US 75165-3120 972 937 9841	Delivery#: 82415821 BOL#: 72520539 CUST PO#: CUST P/N: DLVRY LBS / HEAT: 45060.000 LB DLVRY PCS / HEAT: 720 EA
--	----------------------------	---	----------------------------	--	---

Characteristic	Value	Characteristic	Value	Characteristic	Value
C	0.42%				
Mn	0.75%				
P	0.012%				
S	0.053%				
Si	0.18%				
Cu	0.31%				
Cr	0.16%				
Ni	0.17%				
Mo	0.079%				
V	0.000%				
Cb	0.001%				
Sn	0.012%				
Al	0.002%				
Yield Strength test 1	67.9ksi				
Tensile Strength test 1	103.4ksi				
Elongation test 1	16%				
Elongation Gage Lgth test 1	8IN				
Bend Test Diameter	2.188IN				
Bend Test 1	Passed				
<p>The Following is true of the material represented by this MTR:</p> <ul style="list-style-type: none"> <li>*Material is fully killed</li> <li>*100% melted and rolled in the USA</li> <li>*EN10204:2004 3.1 compliant</li> <li>*Contains no weld repair</li> <li>*Contains no Mercury contamination</li> <li>*Manufactured in accordance with the latest version of the plant quality manual</li> <li>*Meets the "Buy America" requirements of 23 CFR635 410</li> </ul>					

EMARKS :

07-26-2018 07:01 Load - 3104025 BL - 3847189 BLR466  
 Texas Corrugators, Inc Heat - 2801948  
 Cust. PO - M-9195 Order-Line - 16359482 / 6



3525 Richard Arrington, Jr., Blvd. N.  
 Birmingham, Alabama 35294  
 Phone: (205) 251-1884  
 Lab Fax (205) 421-4561  
 Lab@SouthlandTube.com

**TEST REPORT**

Customer Name: KLOECKNER METALS CORPORATION  
 Customer PO No.: 7257246 Customer Part No: T6412RECTA5000576

Spec/Grade: A500-13 Grade B/C	Heat No.: 2801948	
Description: CARBON STEEL TUBING	Print Date: 3/27/2018	
Size/Length: 6" X 4" X 1/2" 45'	Nominal Thickness: 0.500	
Carbon (C): 0.2200	Tin (Sn): 0.0050	Vanadium (V): 0.0050
Manganese (Mn): 0.8200	Nickel (Ni): 0.0300	Columbium (Cb): 0.0000
Phosphorus (P): 0.0070	Chromium (Cr): 0.0300	Titanium (Ti): 0.0010
Sulphur (S): 0.0020	Molybdenum (Mo): 0.0100	Boron (B): 0.0000
Silicon (Si): 0.0200	Aluminum (Al): 0.0240	Calcium (Ca): 0.0020
Copper (Cu): 0.1000	Nitrogen (N): 0.0050	Carbon Equiv. (CE): 0.3743

Sample Number	Sample Date	Tensile (psi)	Yield (psi)	Elongation (%)
SL61201	3/9/2018	81,700	68,700	36.63

We hereby certify that the above figures are correct as contained in the records of this company. Testing, where it is performed, is performed according to applicable standards (Yield Strength determined using 0.2% offset method and Elongation is measured over a 2" gauge length). Finished goods that require destructive testing by either flattening or flaring to meet the requirements of the standard to which they are certified have been destructively tested in accordance with the pertinent standard. Further, this certification is compliant with the EN10204:2004 Standard for Type 3.1 Inspection Documents.

Ron Lowery

Laboratory Manager  
 Southland Tube Incorporated

Melted & Manufactured in the U.S.A.

STI Pickup No.: 03LB266 STI Order No.: 00462830 STI Item No.: 4.0X6.050048

08-09-2018 00:00 Load - 3114657 BL - 3847917 BLR466  
 Texas Corrugators, Inc Heat - C86773  
 Cust. PO - M-9195 Order-Line - 16359482 / 4

Independence Tube  
 a Nucor Company

6226 W. 74th St.  
 Chicago, IL 60638  
 708-496-0380  
 Fax: 708-563-1950

www.independencetube.com  
 itctube.com  
 Certificate Number: CHI 839719

Sold By:  
**INDEPENDENCE TUBE CORPORATION**  
 6226 W. 74th St.  
 Chicago, IL 60638  
 Tel: 708-496-0380  
 Fax: 708-563-1950

Purchase Order No: 7297731  
 Sales Order No: CHI 835183 - 1  
 Bill of Lading No: CHI 170642 - 2  
 Invoice No:

Shipped: 8/3/2018  
 Invoiced:

Sold To:  
 1187 - KLOECKNER METALS CORP- HO/BU  
 500 COLONIAL PARKWAY  
 SUITE 500  
 ROSWELL, GA 30076

Ship To:  
 2 - KLOECKNER METALS CORP BUDA  
 2560 SOUTH LOOP 4  
 BUDA, TX 78610

**CERTIFICATE of ANALYSIS and TESTS**

Certificate No: CHI 839719

Customer Part No:

Test Date: 8/2/2018

TUBING A500 GRADE B(C)  
 7" X 5" X 3/8" X 21'

Total Pieces 16  
 Total Weight 9,284

Bundle Tag	Mill	Heat	Specs	Y/T Ratio	Pieces	Weight
23155	13N	C86773	YLD=64531/TEN=68326/ELG=32.79	0.9445	7	4,040
23154	13N	C86773	YLD=64531/TEN=68326/ELG=32.79	0.9445	9	5,194

Mill #: 13N Heat #: C86773 Carbon Eq: 0.1625 Heat Src Origin: MELTED AND MANUFACTURED IN THE USA

C	Mn	P	S	Si	Al	Cu	Cr	Mo	V	Ni	Nb	Sn
0.0600	0.4100	0.0030	0.0030	0.0300	0.0310	0.1300	0.0800	0.0200	0.0010	0.0800	0.0140	0.0050

N	B	Ti	Ca
0.0063	0.0001	0.0020	0.0022

LEED Information (based on the most recent LEED information from the producing mill)

Method	Location	Recycled Content	Post Consumer	Post Industrial
EAF	Ghent, KY	66.9%	28.2%	38.9%

T/R FAX

Certification:

I certify that the above results are a true and correct copy of records prepared and maintained by Independence Tube Corporation. Sworn this day, 8/2/2018

WE PROUDLY MANUFACTURE ALL OUR PRODUCT IN THE USA. INDEPENDENCE TUBE PRODUCT IS MANUFACTURED, TESTED, AND INSPECTED IN ACCORDANCE WITH ASTM STANDARDS. MATERIAL IDENTIFIED AS A500 GRADE B(C) MEETS BOTH ASTM A500 GRADE B AND A500 GRADE C SPECIFICATIONS.



CURRENT STANDARDS:  
 A252-10  
 A500/A500M-18  
 A513/A513M-15  
 ASTM A53/A53M-12 | ASME SA-53/SA-53M-13  
 AB47/AB47M-14  
 A1085/A1085M-15

Chris Allen, ASQ CMQ/OE  
 Quality Systems Supervisor

Namasco

09-06-2018 04:00 Load - 3134241 BL - 3849492 Heat - JW18107480 BLR466  
 Texas Corrugators, Inc  
 Cust. PO - A-7426 Order-Line - 16409366 / 2

**NUCOR**  
 NUCOR CORPORATION  
 NUCOR STEEL TEXAS

**Mill Certification**  
 8/15/2018

MTR #: J1-423064  
 3812 Hwy 75 W  
 Jewett, TX 75846  
 (903) 626-4461  
 Fax: (903) 626-6290

Sold To: KLOECKNER METALS CORP  
 500 COLONIAL CTR PKWY  
 STE 500  
 ROSWELL, GA 30078  
 (678) 259-8817  
 Fax: (678) 259-8694

Ship To: KLOECKNER METALS  
 2560 S LOOP 4  
 BLUDA, TX 78610  
 (512) 472-5533

Customer P.O.	7297948	Sales Order	278262.18
Product Group	Merchant Bar Quality	Part Number	5325020024004W0
Grade	A36/A529GR50/CSA44W/50W	Lot #	JW1810748001
Size	1/4x2" Flat	Heat #	JW18107480
Product	1/4x2" Flat 20' A36/A529-50/44W/50W	B.L. Number	J1-833419
Description	A36/A529-50/44W/50W	Lead Number	J1-423064
Customer Spec		Customer Part #	MB142FL1MA350240

I hereby certify that the material described herein has been manufactured in accordance with the specifications and standards listed above and that it satisfies those requirements.

Roll Date: 8/14/2018 Mill Date: 8/11/2018 Qty Shipped LBS: 5,103 Qty Shipped Pcs: 150

ASTM A36/A36M-12, A709/709M-10 GR56, ASME SA36-10 Ed '11 Ac.  
 ASME SA36-2010 EDITION-2011 ADDENDA  
 ASTM A709/A709M-12 GR 56 (250)

C	Mn	P	S	Si	Cu	Ni	Cr	Mo	V	Cb
0.14%	0.84%	0.011%	0.025%	0.18%	0.28%	0.17%	0.17%	0.067%	0.0302%	0.002%

Yield 1: 57,400psi Tensile 1: 75,600psi Elongation: 26% in 8"(% in 203.3mm)  
 Yield 2: 57,100psi Tensile 2: 74,900psi Elongation 27% in 8"(% in 203.3mm)

Specification Comments: MEETS THE REQUIREMENTS OF: ASTM A36/A36M-14, A529/A529-05 GR50(345), A709/A709M-10 GR36(250), CSA G40.21-04 GR44W(300W)&GR50W(350W); AASHTO M270/270M-10 GR36(270); ASME SA36/SA36M-10 MEETS REPORTING REQUIREMENTS OF EN10204 SEC 3.1

Comments: E mail: websales@nstexas.com

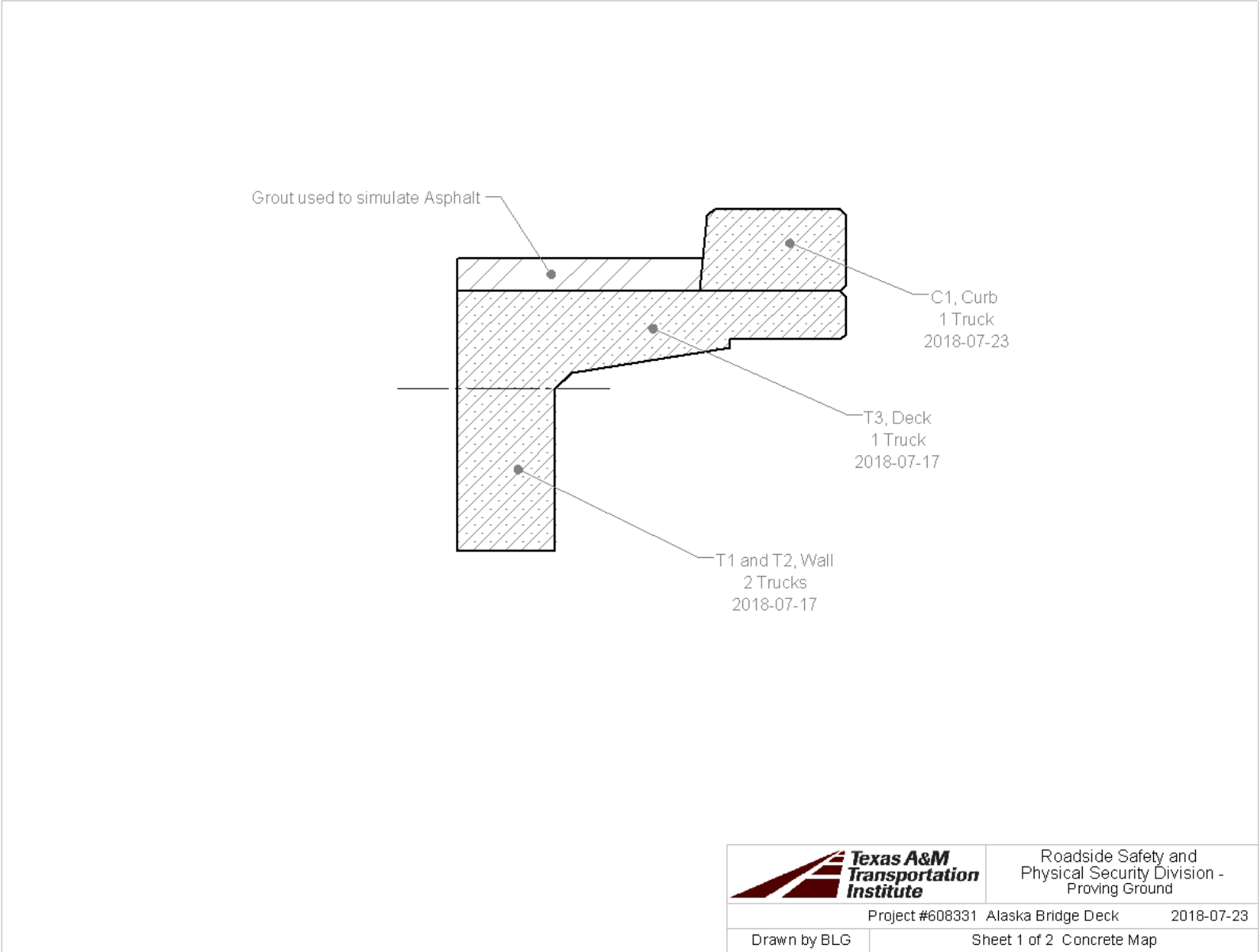
- All manufacturing processes of the steel, including melting, casting & hot rolling, have been performed in U.S.A
- Mercury in any form has not been used in the production or testing of this product.
- Welding or weld repair was not performed on this material.
- This material conforms to the specifications described on this document and may not be reproduced, except in full, without written approval of Nucor Corporation
- Results reported for ASTM E45 (Inclusion content) and ASTM E381 (Macro-etch) are provided as interpretation of ASTM procedures.

*Bhargava R Vantari*

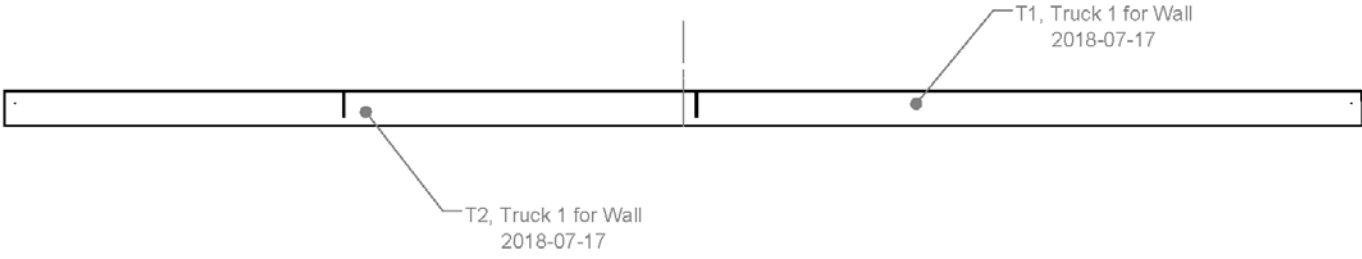
Bhargava R Vantari  
 Division Metallurgist


Page 4 of 5

MSMG-1R October 1, 2017




T:\1-ProjectFiles\608331- Alaska - Williams\Drafting, 608331 1-3\608331, Concrete Map



	Roadside Safety and Physical Security Division - Proving Ground	
	Project #608331 Alaska Bridge Deck	2018-07-23
Drawn by BLG	Scale 1:200	Sheet 2 of 2 Concrete Map 2



 Proving Ground 3100 SH-47, Bldg. 7091 Bryan, TX 77807	Texas A&M University College Station, TX 77843 Phone: 979-845-6376	<b>QC-7.3-01 - Concrete Sampling</b>	Doc. No. QC-7.3-01	Issue Date 2018-06-18
		<b>Quality Form</b>	Prepared by: Wanda L. Menges Approved by: Darrell L. Kuhn	Revision 6

The information contained in this document is confidential to TTI Proving Ground.

Project No: 608331 - Casting Date: 2018-10-26 Mix Design (psi): 4500

Name of Technician Taking Sample: GREG FRITZ      Name of Technician Breaking Sample: Bill Fittell  
 Signature of Technician Taking Sample: [Signature]      Signature of Technician Breaking Sample: [Signature]

Load No.	Truck No.	Ticket No.	Location (from concrete map)
T1	7108	5033773	Near Section of Deck

Load No.	Break Date	Cylinder Age	Total Load (lbs)	Break (psi)	Average
T1	2018-12-10	44 days	167000	5900	1
T1			157500	5570	5670
T1			157000	5550	1





CUSTOMER'S COPY

TICKET NO.



# Martin Marietta

1503 LBJ Freeway  
Suite 400  
Dallas, Tx 75234

5033773



LOAD TIME	TO JOB	ARRIVE JOB SITE	BEGIN POUR	FINISH POUR	LEAVE JOB SITE	ARRIVE PLANT
10:04	10:16	10:30	10:37	10:52	:	:

WATER ADDED ON JOB AT CUSTOMER'S REQUEST 5 GAL.  
 ALLOWABLE WATER (withheld from batch) 5.9 GAL.  
 TEST CYLINDER TAKEN  YES  NO BY \_\_\_\_\_  
 CYLINDER TAKEN  BEFORE  AFTER WATER

CUSTOMER SIGNATURE  
 X (Nick Harker)

**DELIVERY OF THESE MATERIALS IS SUBJECT TO THE TERMS AND CONDITIONS ON THE REVERSE SIDE HEREOF AS ACCEPTED BY SIGNATURE ABOVE.**

**ADDITIONAL WATER ADDED TO THIS CONCRETE WILL REDUCE ITS STRENGTH. ANY WATER ADDED IN EXCESS OF SPECIFIED SLUMP IS AT CUSTOMER'S RISK.**

CUSTOMER NAME AND DELIVERY ADDRESS		PLANT	TRUCK	ORDER NO.	SLUMP	P.O. #/JOB/LOT	GRID
TEXAS A & M UNIVERSI TTI-Riverside Campus		617	7108	2025	5.0	608331	
		DRIVER NAME		DATE			
		Rodney Lucas		10/26/18			
		CUSTOMER NUMBER	PROJECT	CUM. QTY	ORDERED QTY		
		783659	51240	3.00	3.00		

LOAD QUANTITY	PRODUCT CODE	DESCRIPTION	UNIT PRICE	AMOUNT
3.00	CYDS	R9Z50636 COM, RG, Z, 4500, RE		
1.00	ea	12987 FREIGHT CHARGE		

SPECIAL DELIVERY INSTRUCTIONS	SALES TAX
SOUTH 2818, RIGHT ON LEONARD RIGHT ON HWY-47-LEFT INTO RELLIS WILL MEET AT THE ROUND ABOUT	TOTAL

**DANGER!** MAY CAUSE ALKALI BURNS.  
SEE WARNINGS ON REVERSE SIDE.

FOR OFFICE USE ONLY FORM: 2585199

Truck	Driver	User	Disp	Ticket Num	Ticket ID	Time	Date
7108	934548	user	5033773	70726	70726	10:04	10/26/18
Load Size	Mix Code	Returned	Qty	Mix Age	Seq	Load ID	
3.00	CYDS R9Z50636				D	71705	
Material	Design Qty	Required	Batched	% Var	% Moisture	Actual Wat	
1"RG	1365 lb	4109 lb	4120 lb	* 0.26%	0.35% M	2 gl	
3/8"FG	500 lb	1505 lb	1520 lb	* 0.98%	0.35% M	1 gl	
SAND-1	1290 lb	4116 lb	4120 lb	0.05%	5.40% M	27 gl	
CMT-1/11	435 lb	1305 lb	1320 lb	* 1.15%			
FLYASH-C	145 lb	435 lb	430 lb	-1.15%			
100YR	4 oz	13 oz	13 oz	-0.38%			
P80	17 oz	52 oz	52 oz	-0.38%			
H2O	258 lb	440 lb	441 lb	0.16%		53 gl	
Actual	Num Batches: 1						
Load Total:	11955 lb	Design 0.445	Water/Cement 0.442	T	Design 92.8 gl	Actual 81.9 gl	To Add: 5.9 gl
Slump:	5.00 in	# Water in Truck: 5.0 gl	Adjust Water: 0.0 gl	/ Load	Trim Water: -2.0 gl/	CYD	

CUSTOMER'S COPY

TICKET NO.



# Martin Marietta

1503 LBJ Freeway  
Suite 400  
Dallas, Tx 75234

5038332



LOAD TIME	TO JOB	ARRIVE JOB SITE	BEGIN POUR	FINISH POUR	LEAVE JOB SITE	ARRIVE PLANT
1:00	1:12	:	:	:	:	:

WATER ADDED ON JOB AT CUSTOMER'S REQUEST \_\_\_\_\_ GAL.  
 ALLOWABLE WATER (withheld from batch) \_\_\_\_\_ GAL.  
 TEST CYLINDER TAKEN  YES  NO BY \_\_\_\_\_  
 CYLINDER TAKEN  BEFORE  AFTER WATER

CUSTOMER SIGNATURE  
 X  
**DELIVERY OF THESE MATERIALS IS SUBJECT TO THE TERMS AND CONDITIONS ON THE REVERSE SIDE HEREOF AS ACCEPTED BY SIGNATURE ABOVE.**

**ADDITIONAL WATER ADDED TO THIS CONCRETE WILL REDUCE ITS STRENGTH. ANY WATER ADDED IN EXCESS OF SPECIFIED SLUMP IS AT CUSTOMER'S RISK.**

CUSTOMER NAME AND DELIVERY ADDRESS		PLANT	TRUCK	ORDER NO.	SLUMP	P.O. #/JOB/LOT	GRID
TEXAS A & M UNIVERSITY TTI-Riverside Campus		617	7102	2017	5.0	608331	
		DRIVER NAME		DATE			
		Raymont Ortiz		10/29/18			
CUSTOMER NUMBER	PROJECT	CUM. QTY	ORDERED QTY				
783659	51240	3.00	3.00				

LOAD QUANTITY	PRODUCT CODE	DESCRIPTION	UNIT PRICE	AMOUNT
3.00	CYDS	R9250636		
1.00	ea	12987		
		COM, RG, Z, 4500, RE		
		FREIGHT CHARGE		

SPECIAL DELIVERY INSTRUCTIONS: SOUTH 2810, RIGHT LEONARD, RIGHT 47, LEFT INTO RELLIS WILL MEET AT THE ROUND ABOUT

SALES TAX: \_\_\_\_\_  
 TOTAL: \_\_\_\_\_

**DANGER!** MAY CAUSE ALKALI BURNS. SEE WARNINGS ON REVERSE SIDE.

FOR OFFICE USE ONLY FORM: 2585233

Truck	Driver	User	Disp	Ticket Num	Ticket ID	Time	Date
7102	940107	user	5038332	70760		13:00	10/29/18
Load Size	Mix Code	Returned	Qty	Mix Age	Seq	Load ID	
3.00	CYDS R9250636				D	71740	
Material	Design Qty	Required	/Batched	% Var	% Moisture	Actual Wat	
1"RG	1365 lb	4105 lb	4120 lb	0.36%	0.25% M	1 gl	
3/8"PG	500 lb	1503 lb	1520 lb	1.13%	0.20% M	1 gl	
SAND-I	1298 lb	4077 lb	4080 lb	0.06%	4.50% M	22 gl	
CMT-1/11	435 lb	1305 lb	1310 lb	0.38%			
FLYASH-C	145 lb	435 lb	430 lb	-1.15%			
100XR	4 oz	13 oz	13 oz	-0.38%			
P80	17 oz	52 oz	52 oz	-0.38%			
H2O	258 lb	532 lb	534 lb	0.34%		64 gl	
Actual	Num Batches: 1						
Load Total:	11996 lb	Design 0.445	Water/Cement 0.445	T	Design 92.8 gl	Actual 87.6 gl	To Add: 5.2 gl
Slump:	5.00 in	# Water in Truck: 0.0 gl	Adjust Water: 0.0 gl	/ Load	Tris Water: -1.8 gl/ CYD		

*This page intentionally left blank.*

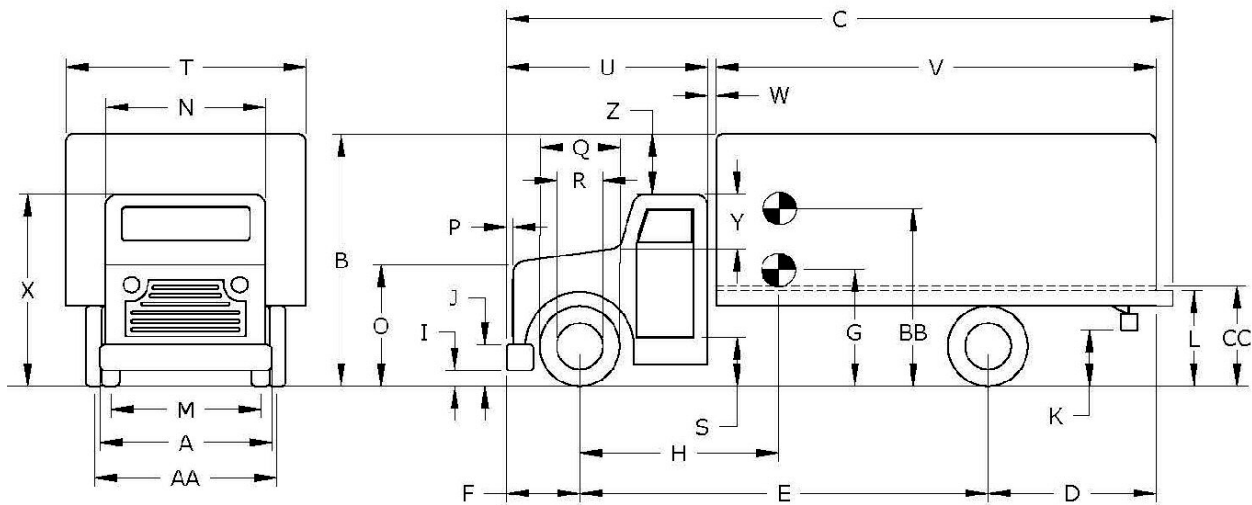


# APPENIDX C. MASH TEST 4-12 (CRASH TEST NO. 608331-01-1A)

## C1 VEHICLE PROPERTIES AND INFORMATION

**Table C.1. Vehicle Properties for Test No. 608331-01-1A.**

Date:	<u>2018-12-10</u>	Test No.:	<u>608331-01-1A</u>	VIN No.:	<u>1H9MMAANOBJ440340</u>
Year:	<u>2011</u>	Make:	<u>International</u>	Model:	<u>4300</u>
Odometer:	<u>101136</u>	Tire Size Front:	<u>275/80R22.5</u>	Tire Size Rear:	<u>275/80R22.5</u>



Vehicle Geometry:		<input checked="" type="checkbox"/> inches	or	<input type="checkbox"/> mm		
A	Front Bumper Width:	95.00		K	Rear Bumper Bottom:	
B	Overall Height:	143		L	Rear Frame Top:	37.00
C	Overall Length:	327.25		M	Front Track Width:	80.00
D	Rear Overhang:	86.50		N	Roof Width:	71.00
E	Wheel Base:	204.75		O	Hood Height:	59.00
F	Front Overhang:	36.00		P	Bumper Extension:	1.00
G	C.G. Height:			Q	Front Tire Width:	39.00
H	C.G. Horizontal Dist. w/Ballast:	125.35		R	Front Wheel Width:	23.50
I	Front Bumper Bottom:	19.00		S	Bottom Door Height:	37.50
J	Front Bumper Top:	34.00		T	Overall Width:	96.00
				U	Cab Length:	106.00
				V	Trailer/Box Length:	222.50
				W	Gap Width:	1.75
				X	Overall Front Height:	98.50
				Y	Roof-Hood Distance:	30.00
				Z	Roof-Box Height Difference:	34.00
				AA	Rear Track Width:	73.00
				BB	Ballast Center of Mass:	61.25
				CC	Cargo Bed Height:	48.25

Allowable Range: C = 394 inches max.; E = 240 inches max.; CC = 51 ±2 inches; BB = 63 ±2 inches above ground;

Wheel Center Height Front	19.00	Wheel Well Clearance (Front)	9.00	Bottom Frame Height (Front)	25.50
Wheel Center Height Rear	19.00	Wheel Well Clearance (Rear)	3.50	Bottom Frame Height (Rear)	27.00



**Table C.1. Vehicle Properties for Test No. 608331-1A (Continued).**

Date: 2018-12-10 Test No.: 608331-01-1A VIN No.: 1H9MMAANOBJ440340  
 Year: 2011 Make: International Model: 4300

**WEIGHTS**  
 ( lb or  kg)

	<b>CURB</b>	<b>TEST INERTIAL</b>
W <sub>front axle</sub>	<u>7280</u>	<u>8550</u>
W <sub>rear axle</sub>	<u>6720</u>	<u>13500</u>
W <sub>TOTAL</sub>	<u>14000</u>	<u>22050</u>

**Allowable Range for CURB = 13,200 ±2200 lb | Allowable Range for TIM = 22,046 ±660 lb**

Ballast: 8050 ( lb or  kg) **(as-needed)**  
**(See MASH Section 4.2.1.2 for recommended ballasting)**

**Mass Distribution**

( lb or  kg): **LF:** 4260 **RF:** 4290 **LR:** 7080 **RR:** 6420

Engine Type: MAXX FORCE DIESEL Accelerometer Locations ( inches or  mm)  
 Engine Size: DT 466 **x<sup>1</sup>** **y** **z<sup>2</sup>**

Transmission Type:  
 Auto or  Manual  
 FWD  RWD  4WD

	<b>Front:</b>		
<b>Center:</b>	<u>125.35</u>	<u>0.00</u>	<u>48.00</u>
<b>Rear:</b>	<u>225.35</u>	<u>0.00</u>	<u>48.00</u>

Describe any damage to the vehicle prior to test: \_\_\_\_\_  
 \_\_\_\_\_  
 \_\_\_\_\_

**Other notes to include ballast type, dimensions, mass, location, center of mass, and method of attachment:**

Block 1: Height 30 inches / Width 60 inches / Length 30 inches  
Block 2: Height 30 inches / Width 60 inches / Length 30 inches  
Blocks centered in middle of bed  
61.25 inches center of load to ground  
Four 5/16-inch cables per block

Performed by: SCD Date: 2018-12-10

<sup>1</sup> Referenced to the front axle  
<sup>2</sup> Above ground

**C2 SEQUENTIAL PHOTOGRAPHS**



0.000 s



0.100 s



0.200 s



0.300 s



**Figure C.1. Sequential Photographs for Test No. 608331-01-1A (Overhead and Frontal Views).**





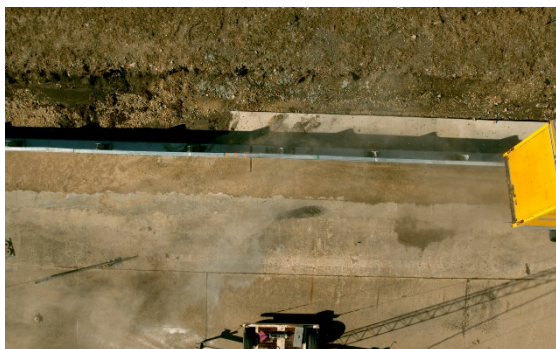
0.400 s



0.500 s



0.600 s



0.700 s



**Figure C.1. Sequential Photographs for Test No. 608331-01-1A (Overhead and Frontal Views) (Continued).**





0.000 s



0.400 s



0.100 s



0.500 s



0.200 s



0.600 s



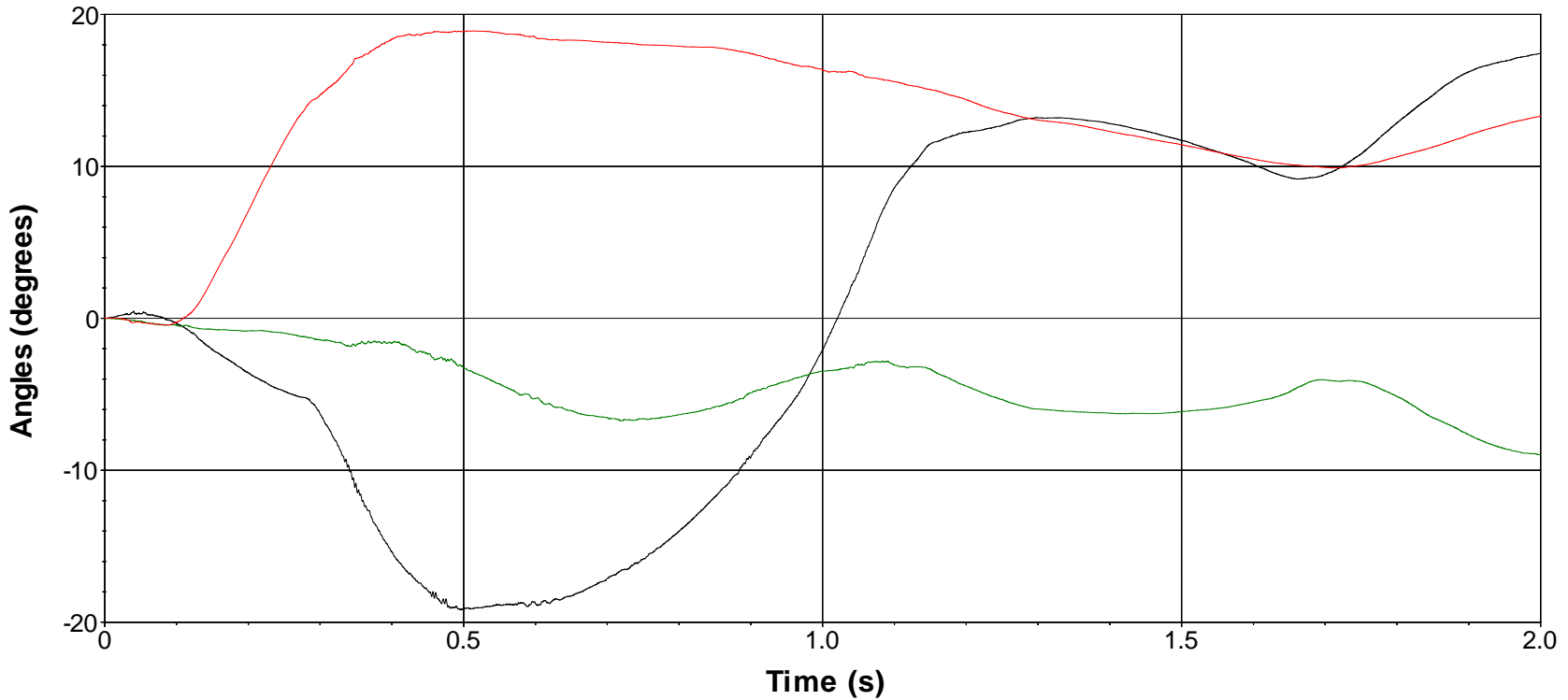
0.300 s



0.700 s

**Figure C.2. Sequential Photographs for Test No. 608331-01-1A (Rear View).**

### Roll, Pitch, and Yaw Angles



— Roll — Pitch — Yaw

Test Number: 608331-01-1A  
 Test Standard Test Number: MASH Test 4-12  
 Test Article: 2019 MASH 2-Tube Bridge Rail  
 Test Vehicle: 2011 International 4300  
 Inertial Mass: 22,050 lb  
 Gross Mass: 22,050 lb  
 Impact Speed: 57.4 mi/h  
 Impact Angle: 15.5°

Axes are vehicle-fixed.  
 Sequence for determining orientation:

1. Yaw.
2. Pitch.
3. Roll.

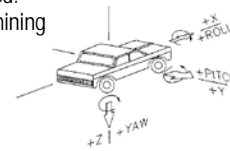


Figure C.3. Vehicle Angular Displacements for Test No. 608331-01-1A.

### X Acceleration at CG

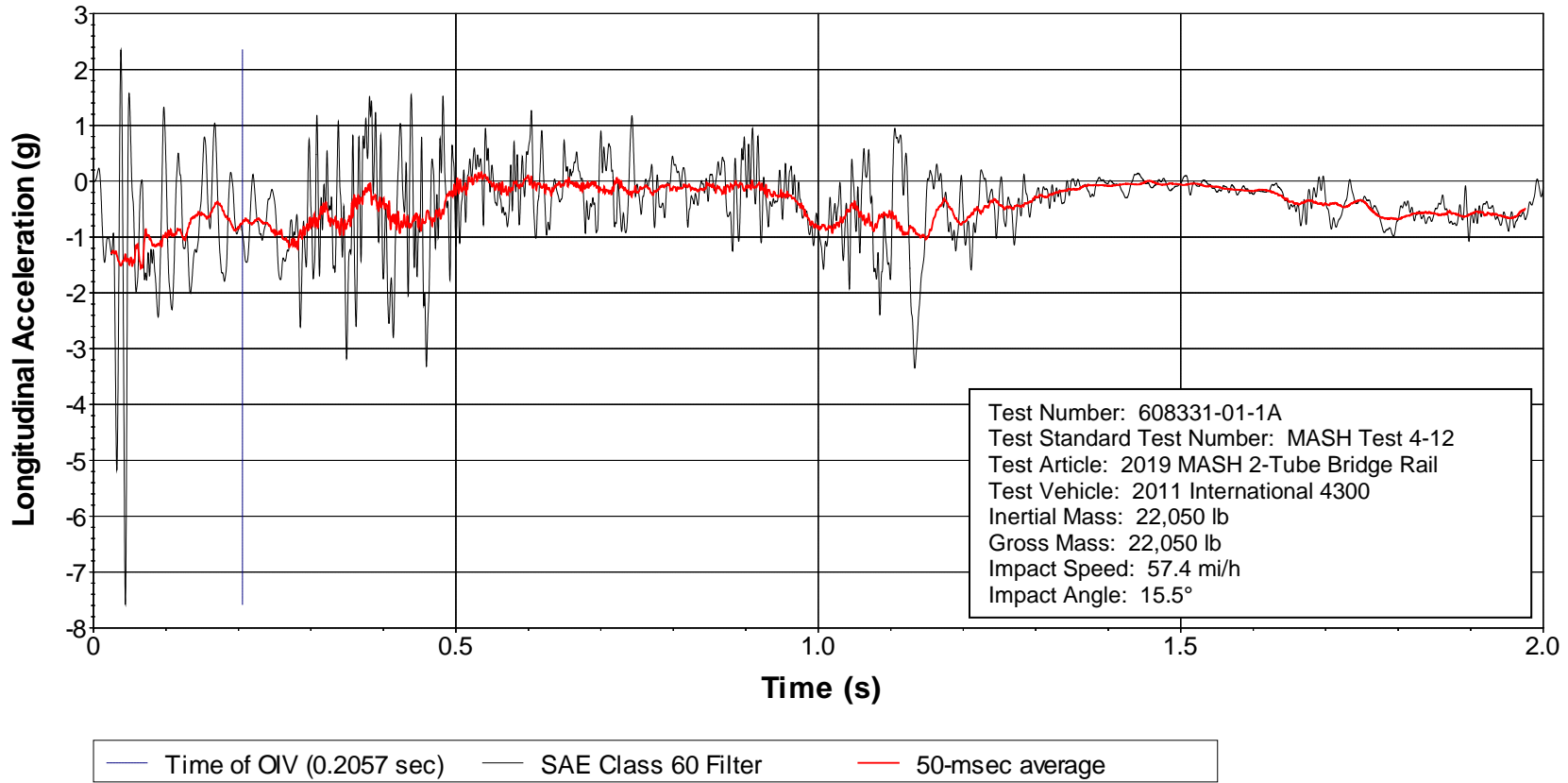
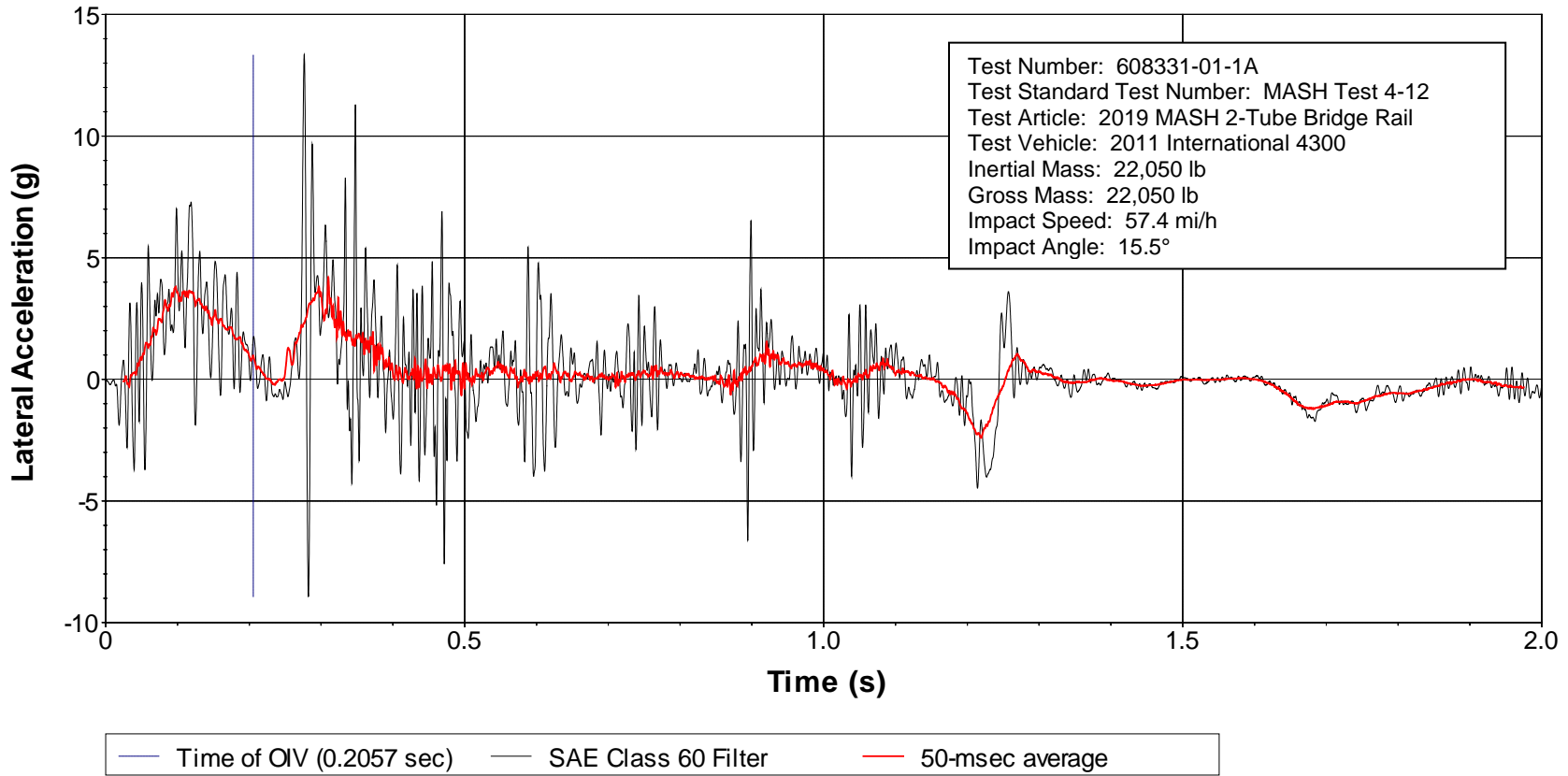


Figure C.4. Vehicle Longitudinal Accelerometer Trace for Test No. 608331-01-1A (Accelerometer Located at Center of Gravity).

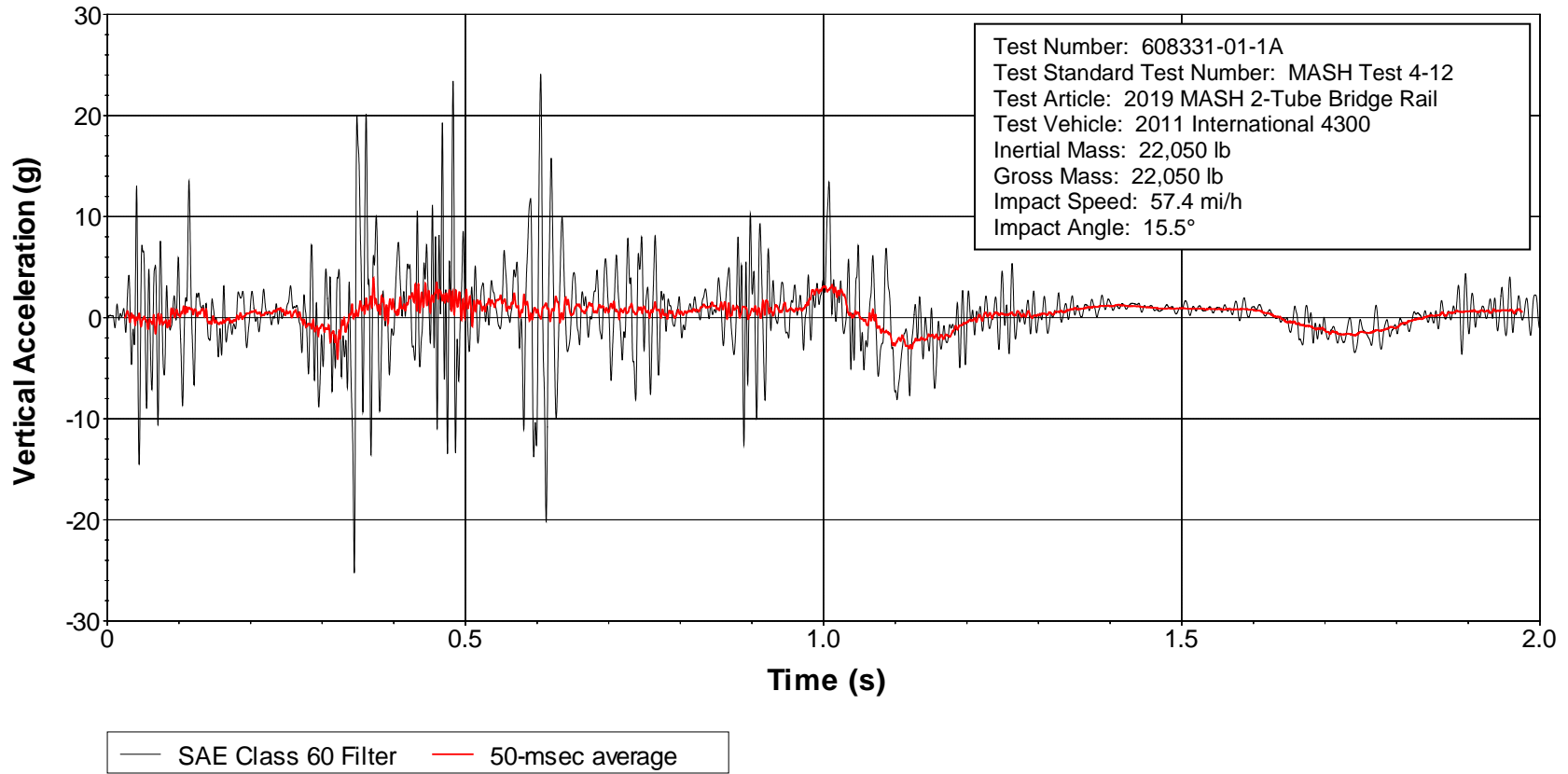


### Y Acceleration at CG



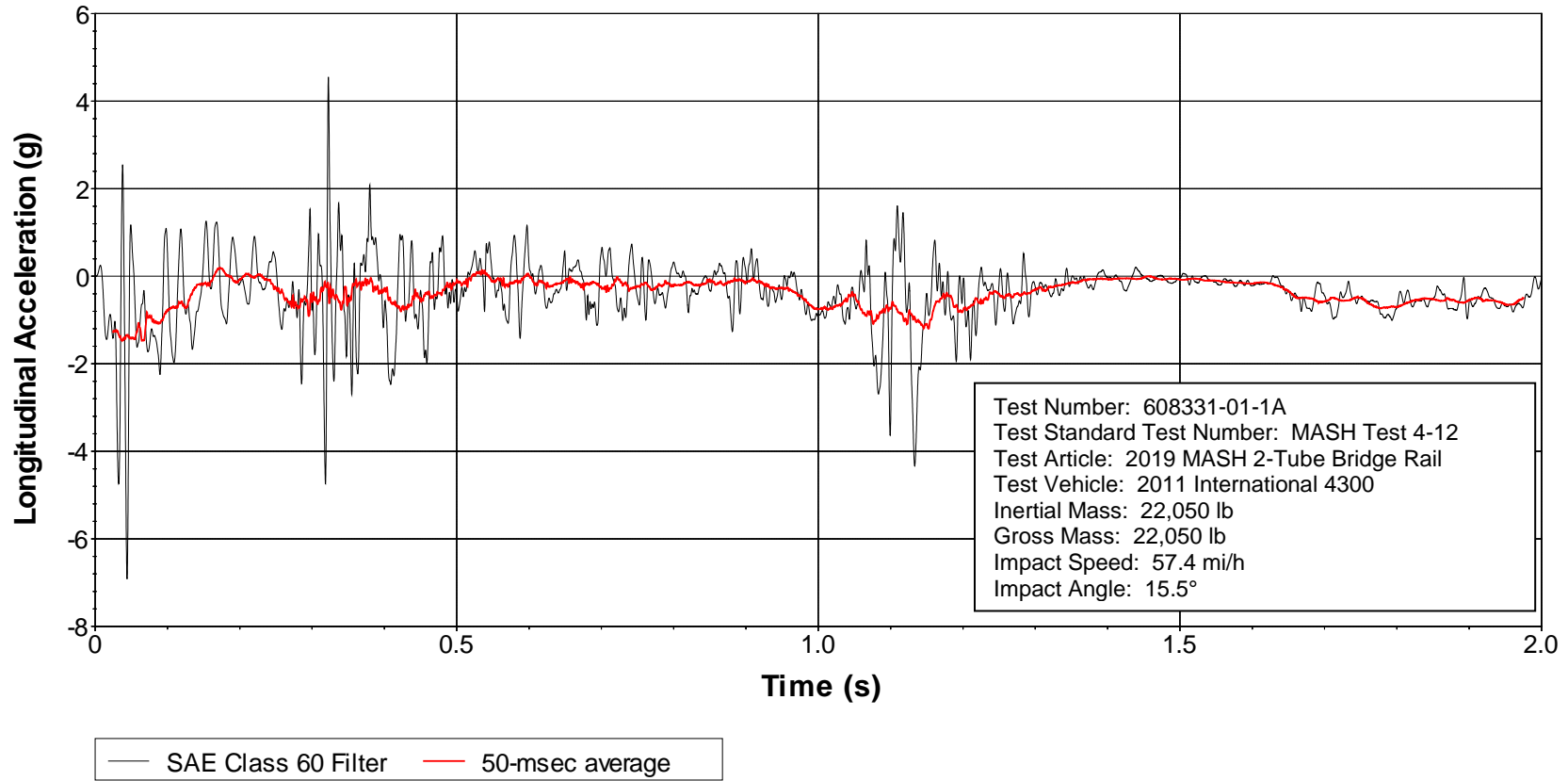
**Figure C.5. Vehicle Lateral Accelerometer Trace for Test No. 608331-01-1A (Accelerometer Located at Center of Gravity).**

### Z Acceleration at CG

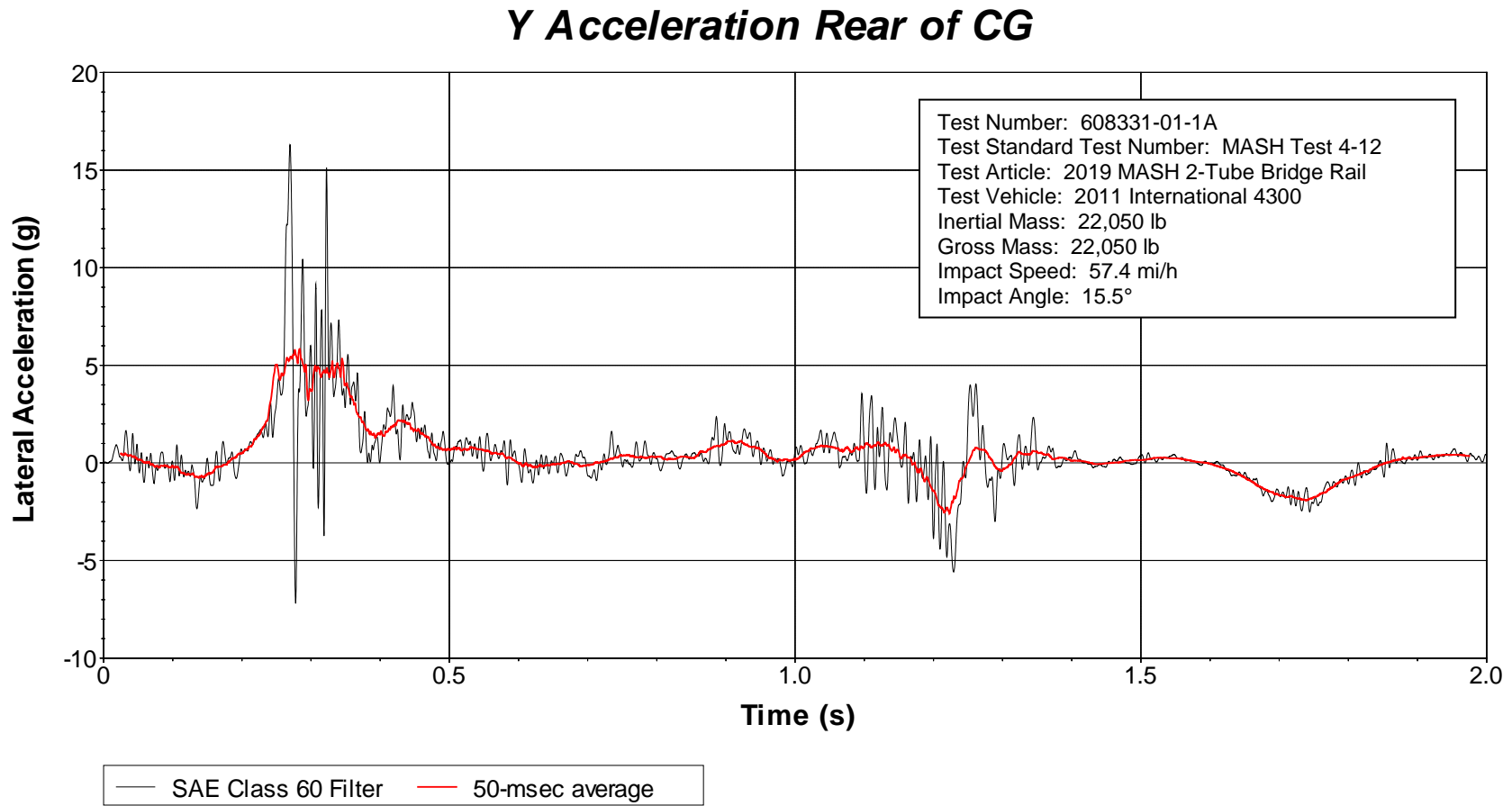


**Figure C.6. Vehicle Vertical Accelerometer Trace for Test No. 608331-01-1A (Accelerometer Located at Center of Gravity).**

### X Acceleration Rear of CG

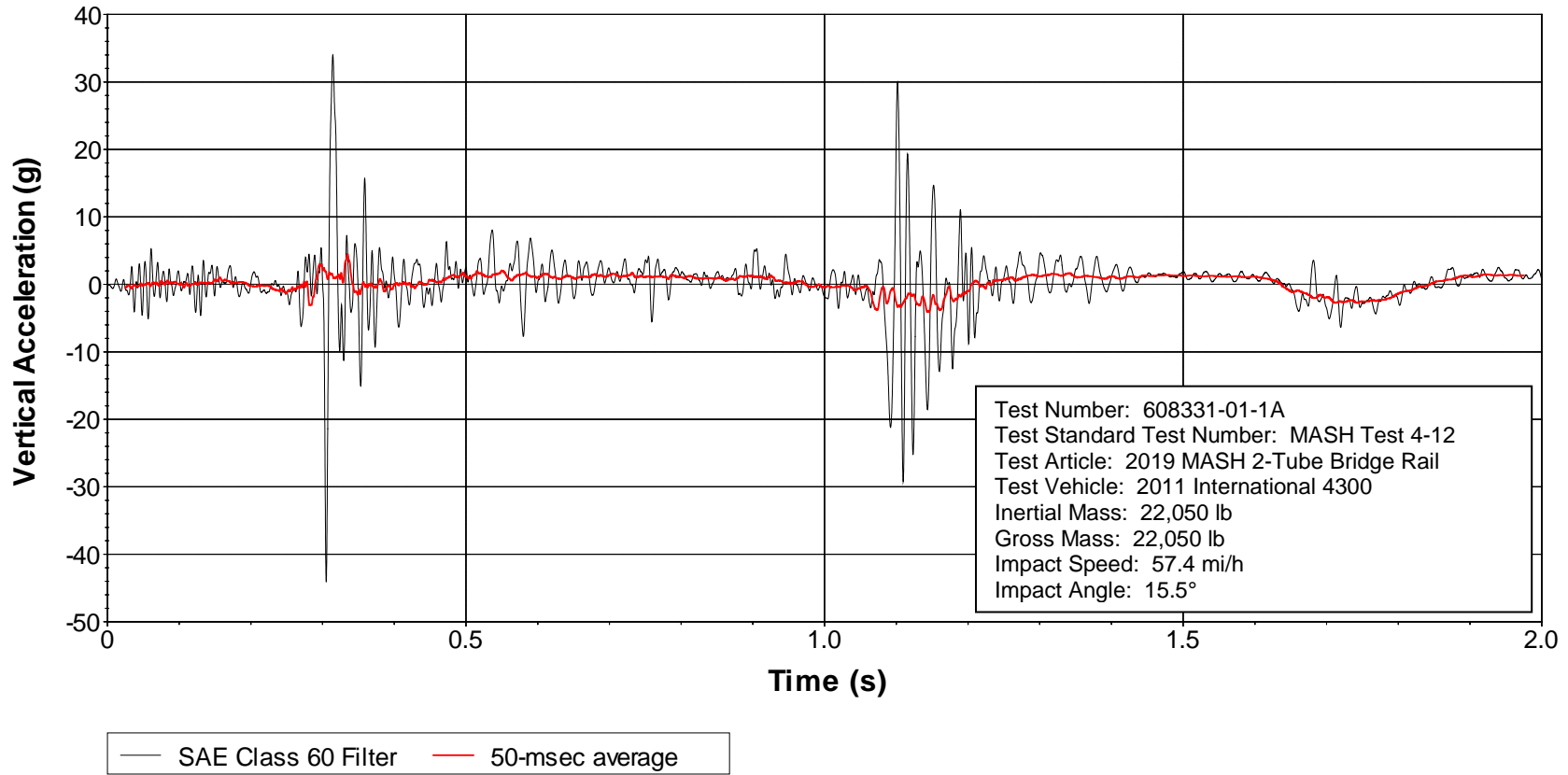


**Figure C.7. Vehicle Longitudinal Accelerometer Trace for Test No. 608331-01-1A (Accelerometer Located Rear of Center of Gravity).**



**Figure C.8. Vehicle Lateral Accelerometer Trace for Test No. 608331-01-1A  
(Accelerometer Located Rear of Center of Gravity).**

### Z Acceleration Rear of CG



**Figure C.9. Vehicle Vertical Accelerometer Trace for Test No. 608331-01-1A (Accelerometer Located Rear of Center of Gravity).**



# APPENDIX D. MASH TEST 4-11 (CRASH TEST NO. 608331-01-2)

## D1 VEHICLE PROPERTIES AND INFORMATION

**Table D.1. Vehicle Properties for Test No. 608331-01-2.**

Date: 2018-12-12 Test No.: 608331-01-2 VIN No.: 1C6RD6FT5CS132574  
 Year: 2012 Make: RAM Model: 1500  
 Tire Size: 265/70 R 17 Tire Inflation Pressure: 35 psi  
 Tread Type: Highway Odometer: 168353  
 Note any damage to the vehicle prior to test: None

• Denotes accelerometer location.

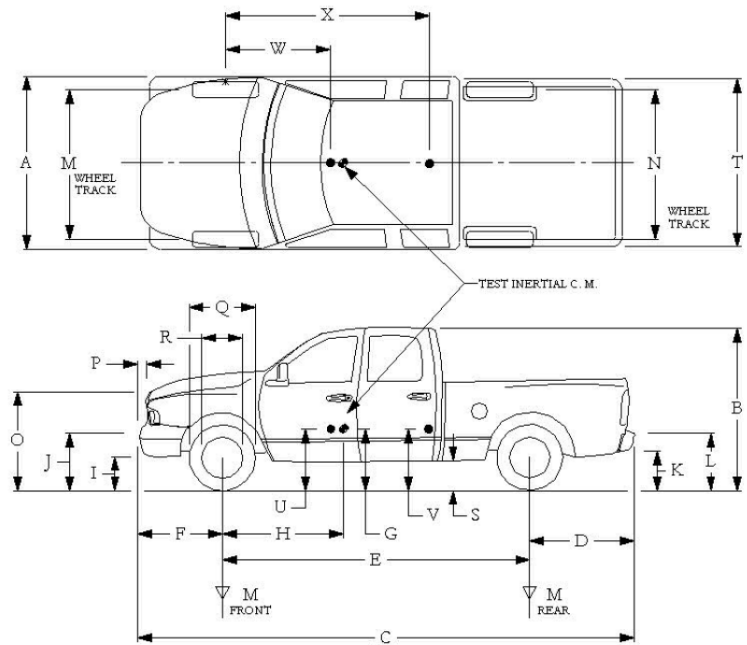
NOTES: None

Engine Type: V-8  
 Engine CID: 4.7 liter

Transmission Type:  
 Auto or  Manual  
 FWD  RWD  4WD

Optional Equipment:  
None

Dummy Data:  
 Type: 50th Percentile Male  
 Mass: 165 lb  
 Seat Position: Driver Side



**Geometry:** inches

A	78.50	F	40.00	K	20.00	P	3.00	U	27.75
B	74.00	G	29.00	L	30.00	Q	30.50	V	30.50
C	227.50	H	62.60	M	68.50	R	18.00	W	62.60
D	44.00	I	11.75	N	68.00	S	13.00	X	78.00
E	140.50	J	27.00	O	46.00	T	77.00		
Wheel Center Height Front	14.75	Wheel Well Clearance (Front)	6.00	Bottom Frame Height - Front	12.50				
Wheel Center Height Rear	14.75	Wheel Well Clearance (Rear)	9.25	Bottom Frame Height - Rear	22.50				

RANGE LIMIT: A=78 ±2 inches; C=237 ±13 inches; E=148 ±12 inches; F=39 ±3 inches; G = > 28 inches; H = 63 ±4 inches; O=43 ±4 inches; M+N/2=67 ±1.5 inches

GVWR Ratings:	Mass: lb	Curb	Test Inertial	Gross Static
Front	<u>3700</u>	<u>2869</u>	<u>2782</u>	<u>2867</u>
Back	<u>3900</u>	<u>2033</u>	<u>2237</u>	<u>2317</u>
Total	<u>6700</u>	<u>4902</u>	<u>5019</u>	<u>5184</u>

(Allowable Range for TIM and GSM = 5000 lb ±110 lb)

**Mass Distribution:**

lb	LF: <u>1396</u>	RF: <u>1386</u>	LR: <u>1132</u>	RR: <u>1105</u>
----	-----------------	-----------------	-----------------	-----------------

**Table D.2. Measurements of Vehicle Vertical CG for Test No. 608331-01-2.**

Date: 2018-12-12 Test No.: 608331-01-2 VIN: 1C6RD6FT5CS132574  
 Year: 2012 Make: RAM Model: 1500  
 Body Style: Quad Cab Mileage: 168353  
 Engine: 4.7 liter V-8 Transmission: Automatic  
 Fuel Level: Empty Ballast: 209 (440 lb max)  
 Tire Pressure: Front: 35 psi Rear: 35 psi Size: 265/70 R 17

Measured Vehicle Weights: (lb)					
LF:	1396	RF:	1386	Front Axle:	2782
LR:	1132	RR:	1105	Rear Axle:	2237
Left:	2528	Right:	2491	Total:	5019
5000 ±110 lb allowed					
Wheel Base:	140.50	inches	Track: F:	68.50	inches
148 ±12 inches allowed			R:	68.00	inches
Track = (F+R)/2 = 67 ±1.5 inches allowed					
Center of Gravity, SAE J874 Suspension Method					
X:	62.62	inches	Rear of Front Axle	(63 ±4 inches allowed)	
Y:	-0.25	inches	Left -	Right +	of Vehicle Centerline
Z:	29.00	inches	Above Ground	(minimum 28.0 inches allowed)	

Hood Height: 46.00 inches Front Bumper Height: 27.00 inches  
 43 ±4 inches allowed

Front Overhang: 40.00 inches Rear Bumper Height: 30.00 inches  
 39 ±3 inches allowed

Overall Length: 227.50 inches  
 237 ±13 inches allowed

**Table D.3. Exterior Crush Measurements for Test No. 608331-01-2.**

Date: 2018-12-12 Test No.: 608331-01-2 VIN No.: 1C6RD6FT5CS132574  
 Year: 2012 Make: RAM Model: 1500

**VEHICLE CRUSH MEASUREMENT SHEET<sup>1</sup>**

Complete When Applicable	
End Damage	Side Damage
Undeformed end width _____	Bowing: B1 _____ X1 _____
Corner shift: A1 _____	B2 _____ X2 _____
A2 _____	
End shift at frame (CDC)	Bowing constant
(check one)	$\frac{X1 + X2}{2} =$ _____
< 4 inches _____	
≥ 4 inches _____	

Note: Measure C<sub>1</sub> to C<sub>6</sub> from Driver to Passenger Side in Front or Rear Impacts – Rear to Front in Side Impacts.

Specific Impact Number	Plane* of C-Measurements	Direct Damage		Field L**	C <sub>1</sub>	C <sub>2</sub>	C <sub>3</sub>	C <sub>4</sub>	C <sub>5</sub>	C <sub>6</sub>	±D
		Width*** (CDC)	Max**** Crush								
1	AT FT BUMPER	19	8	20	8	4	2	--	--	--	-27
2	ABOVE FT BUMPER	19	11	60	1	2	4	6	9	11	+75
	Measurements recorded										
	<input checked="" type="checkbox"/> inches or <input type="checkbox"/> mm										

<sup>1</sup>Table taken from National Accident Sampling System (NASS).

\*Identify the plane at which the C-measurements are taken (e.g., at bumper, above bumper, at sill, above sill, at beltline, etc.) or label adjustments (e.g., free space).

Free space value is defined as the distance between the baseline and the original body contour taken at the individual C locations. This may include the following: bumper lead, bumper taper, side protrusion, side taper, etc. Record the value for each C-measurement and maximum crush.

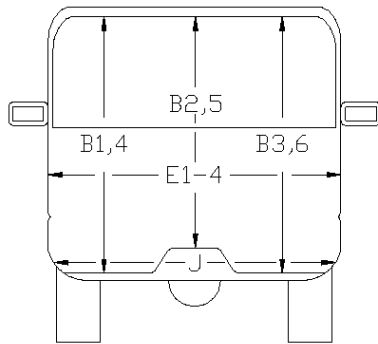
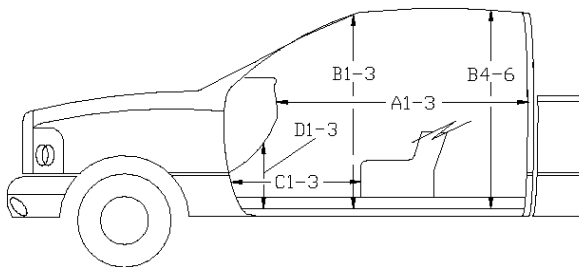
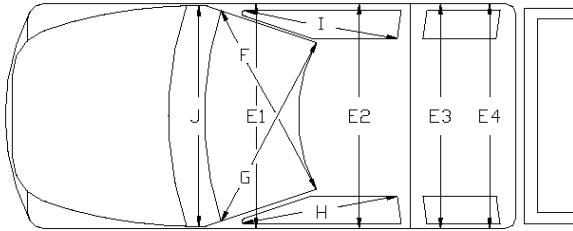
\*\*Measure and document on the vehicle diagram the beginning or end of the direct damage width and field L (e.g., side damage with respect to undamaged axle).

\*\*\*Measure and document on the vehicle diagram the location of the maximum crush.

Note: Use as many lines/columns as necessary to describe each damage profile.

**Table D.4. Occupant Compartment Measurements for Test No. 608331-01-2.**

Date: 2018-12-12 Test No.: 608331-01-2 VIN No.: 1C6RD6FT5CS132574  
 Year: 2012 Make: RAM Model: 1500



**OCCUPANT COMPARTMENT DEFORMATION MEASUREMENT**

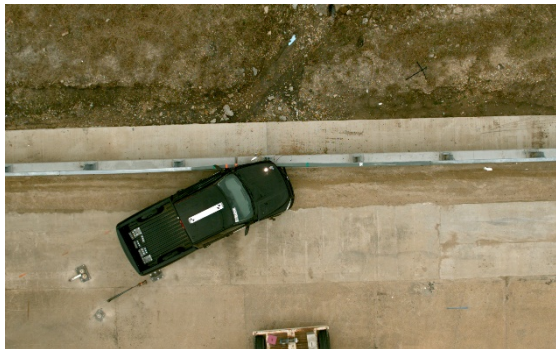
	Before	After (inches)	Differ.
A1	65.00	65.00	0.00
A2	63.00	63.00	0.00
A3	65.50	65.50	0.00
B1	45.00	45.00	0.00
B2	38.00	38.00	0.00
B3	45.00	45.00	0.00
B4	39.50	39.50	0.00
B5	43.00	43.00	0.00
B6	39.50	39.50	0.00
C1	26.00	25.50	-0.50
C2	0.00	0.00	0.00
C3	26.00	26.00	0.00
D1	11.00	11.00	0.00
D2	0.00	0.00	0.00
D3	11.50	11.50	0.00
E1	58.50	58.50	0.00
E2	63.50	63.50	0.00
E3	63.50	63.50	0.00
E4	63.50	63.50	0.00
F	59.00	59.00	0.00
G	59.00	59.00	0.00
H	37.50	37.50	0.00
I	37.50	37.50	0.00
J*	25.00	24.75	-0.25

\*Lateral area across the cab from driver's side kickpanel to passenger's side kickpanel.

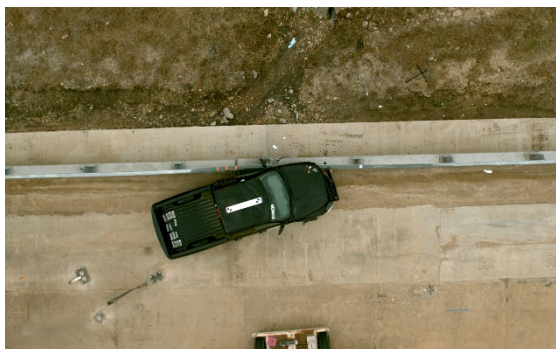
**D2 SEQUENTIAL PHOTOGRAPHS**



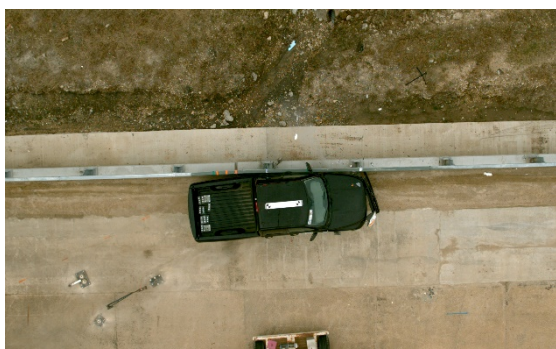
0.000 s



0.050 s



0.100 s

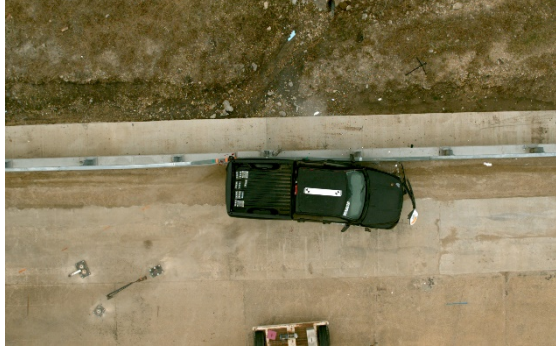


0.150 s



**Figure D.1. Sequential Photographs for Test No. 608331-01-2 (Overhead and Frontal Views).**





0.200 s



0.250 s



0.300 s



0.350 s



**Figure C.1. Sequential Photographs for Test No. 608331-01-2 (Overhead and Frontal Views) (Continued).**





0.000 s



0.200 s



0.050 s



0.250 s



0.100 s



0.300 s



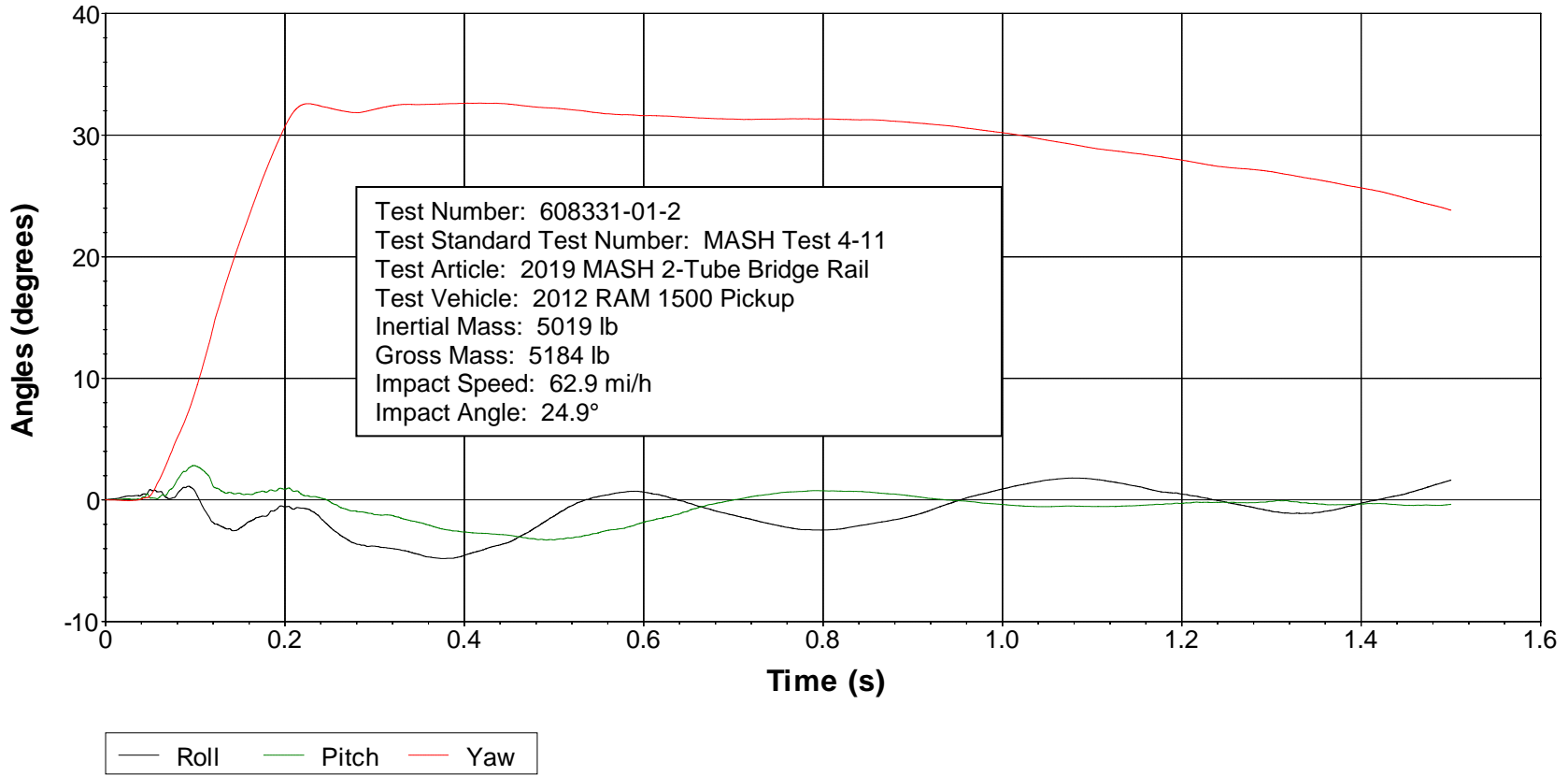
0.150 s



0.350 s

**Figure D.2. Sequential Photographs for Test No. 608331-01-2 (Rear View).**

### Roll, Pitch, and Yaw Angles



Axes are vehicle-fixed.  
Sequence for determining orientation:

1. Yaw.
2. Pitch.
3. Roll.

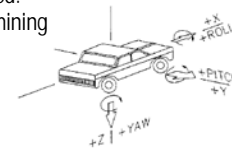
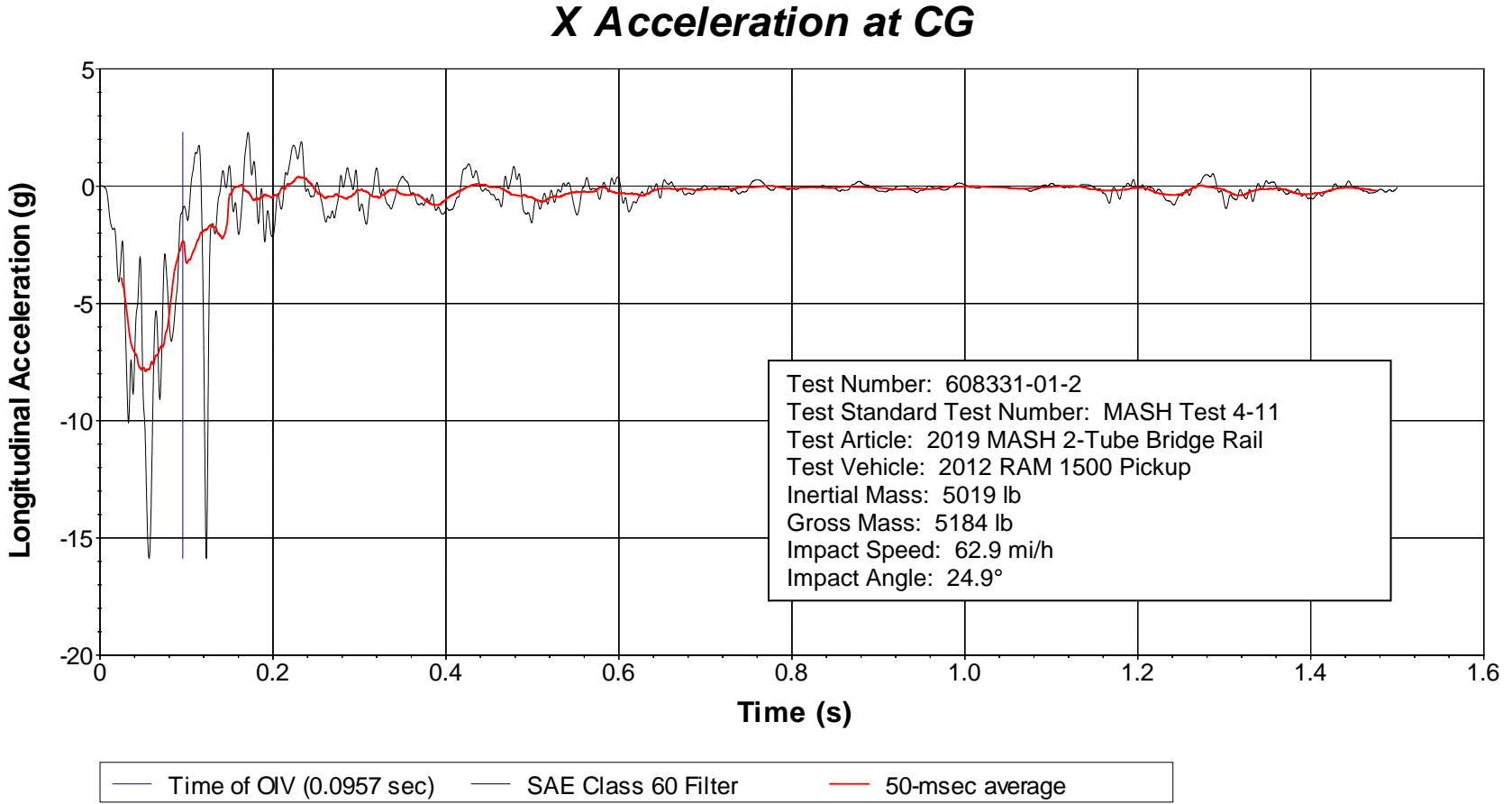
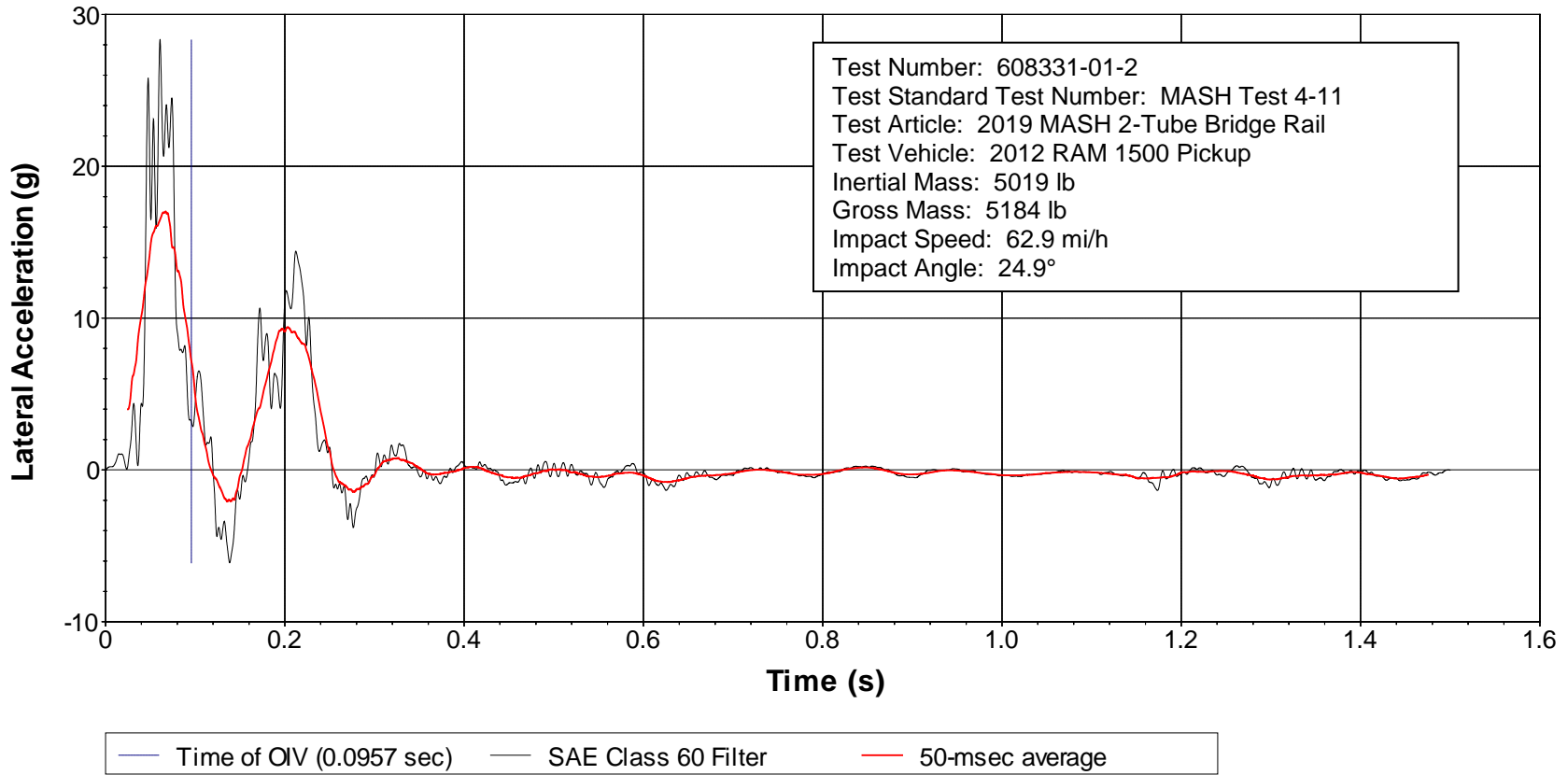


Figure D.3. Vehicle Angular Displacements for Test No. 608331-01-2.

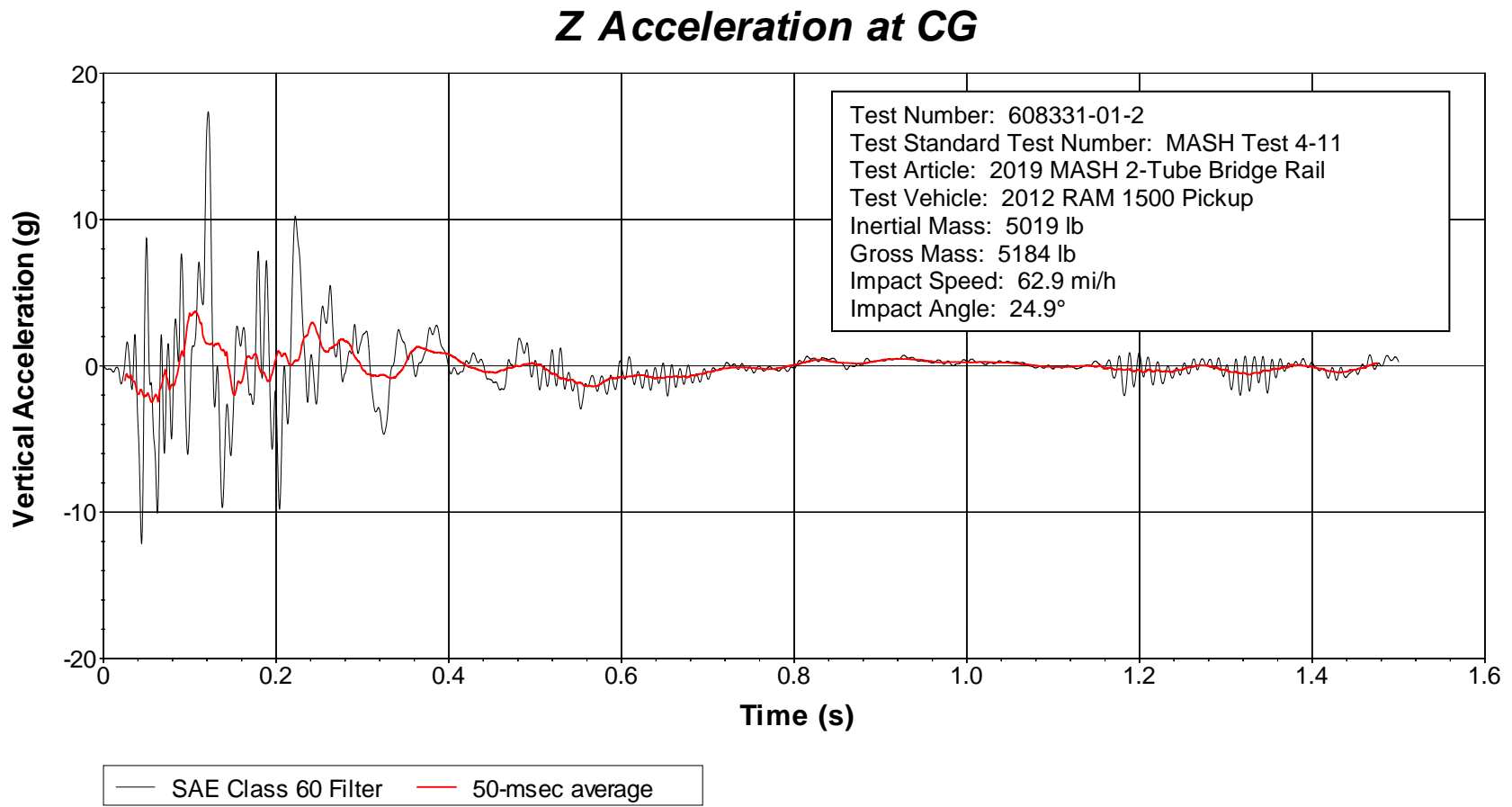


**Figure D.4. Vehicle Longitudinal Accelerometer Trace for Test No. 608331-01-2 (Accelerometer Located at Center of Gravity).**

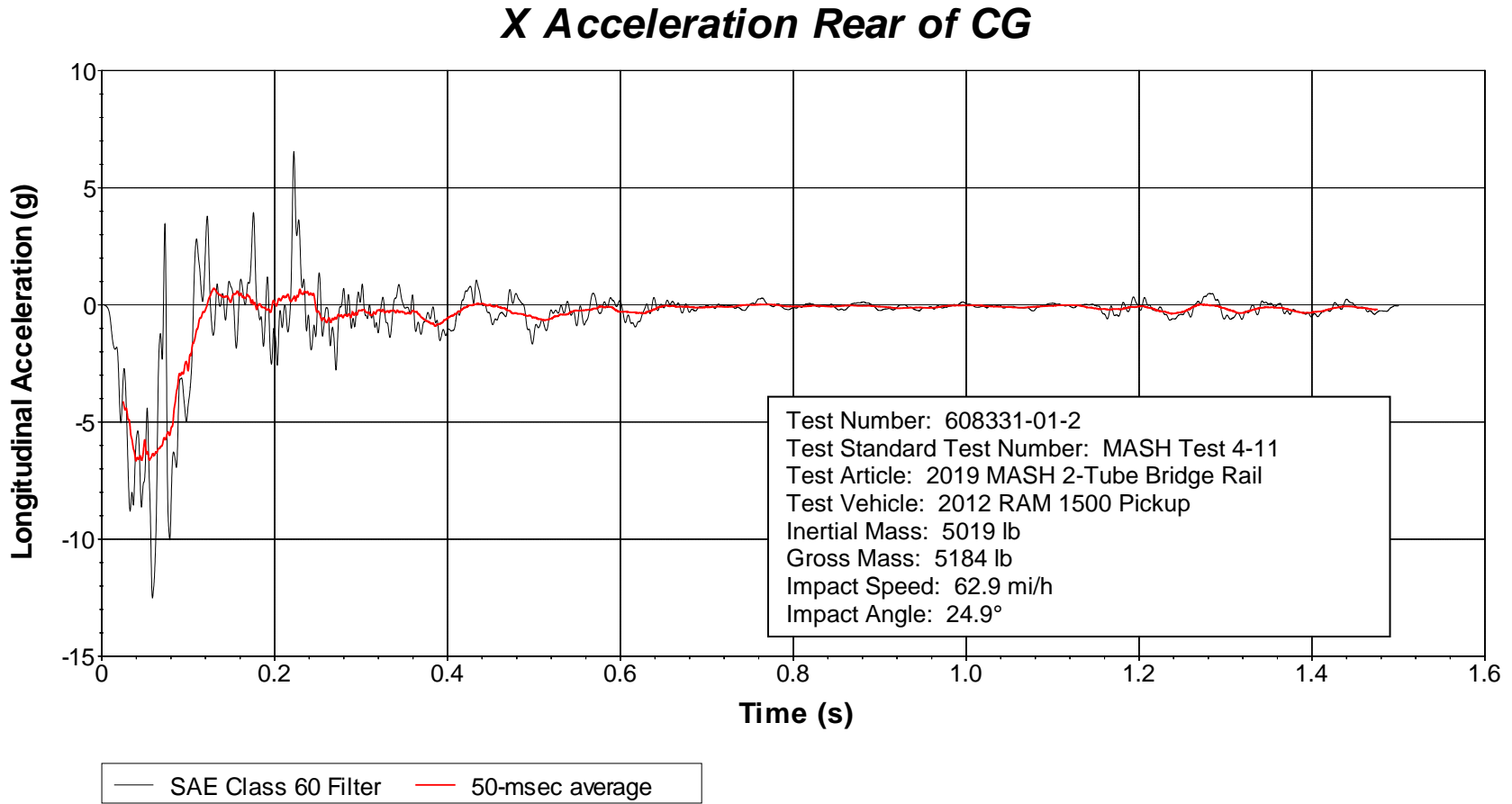
### Y Acceleration at CG



**Figure D.5. Vehicle Lateral Accelerometer Trace for Test No. 608331-01-2 (Accelerometer Located at Center of Gravity).**



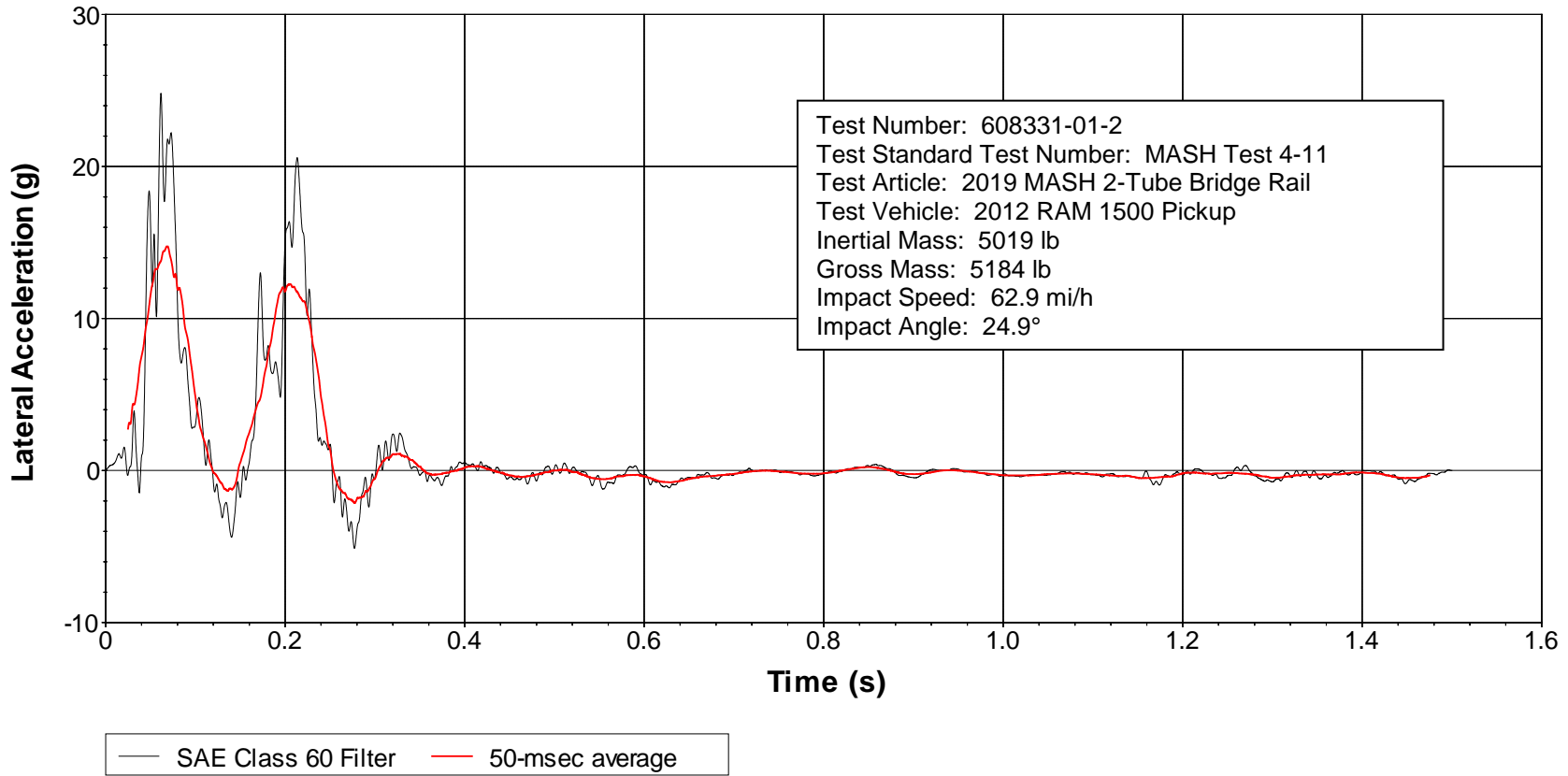
**Figure D.6. Vehicle Vertical Accelerometer Trace for Test No. 608331-01-2 (Accelerometer Located at Center of Gravity).**



**Figure D.7. Vehicle Longitudinal Accelerometer Trace for Test No. 608331-01-2  
 (Accelerometer Located Rear of Center of Gravity).**

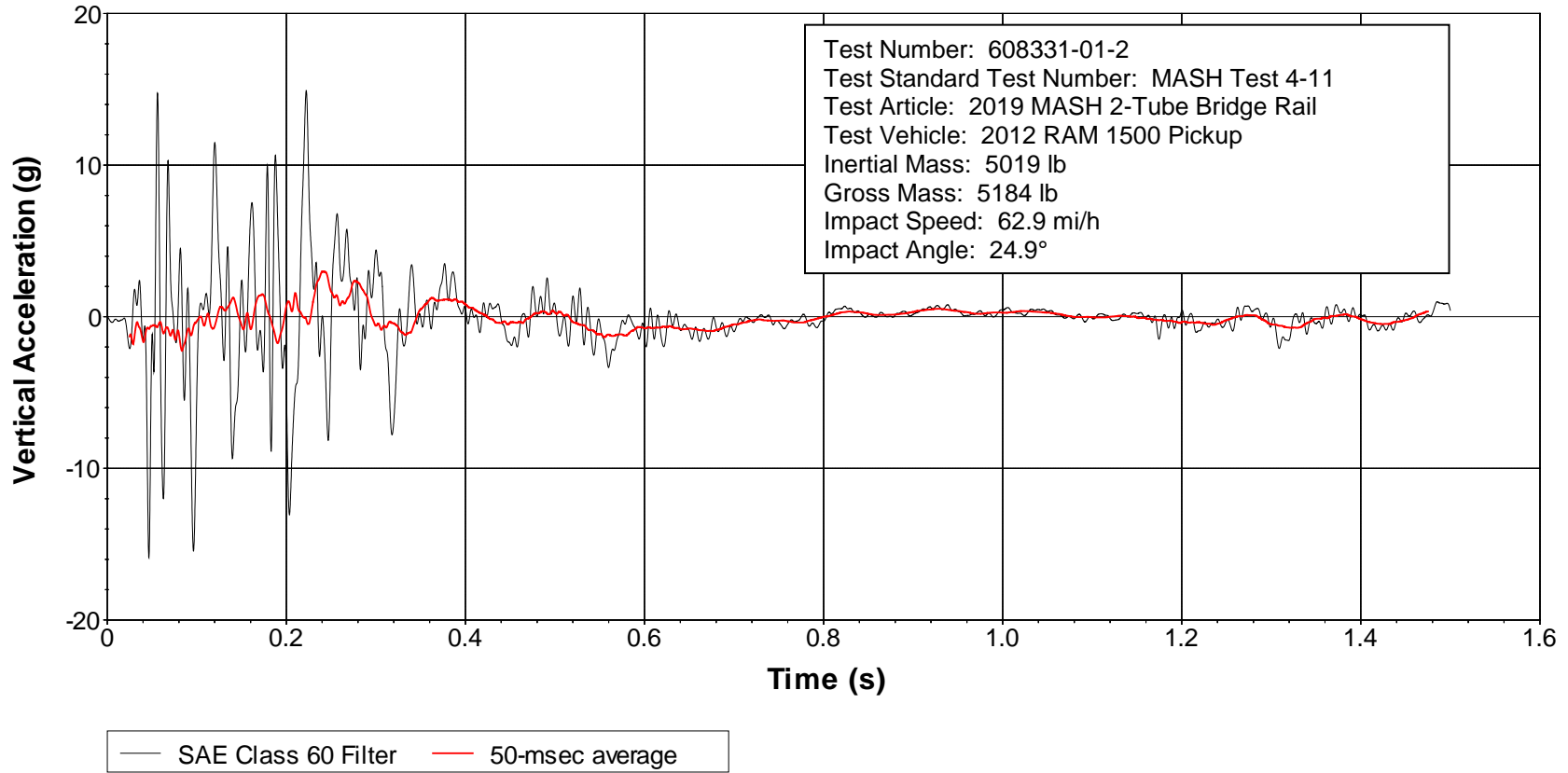


### Y Acceleration Rear of CG



**Figure D.8. Vehicle Lateral Accelerometer Trace for Test No. 608331-01-2 (Accelerometer Located Rear of Center of Gravity).**

### Z Acceleration Rear of CG



**Figure D.9. Vehicle Vertical Accelerometer Trace for Test No. 608331-01-2 (Accelerometer Located Rear of Center of Gravity).**

# APPENIDX E. MASH TEST 4-10 (CRASH TEST NO. 608331-01-3)

## E1 VEHICLE PROPERTIES AND INFORMATION

**Table E.1. Vehicle Properties for Test No. 608331-01-3.**

Date: 2018-12-14 Test No.: 608331-01-3 VIN No.: KNADH4A3XA6680107  
 Year: 2010 Make: Kia Model: Rio  
 Tire Inflation Pressure: 32 psi Odometer: 166024 Tire Size: 185/65R14

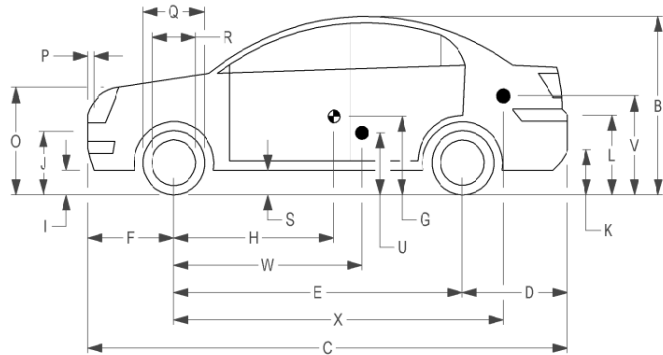
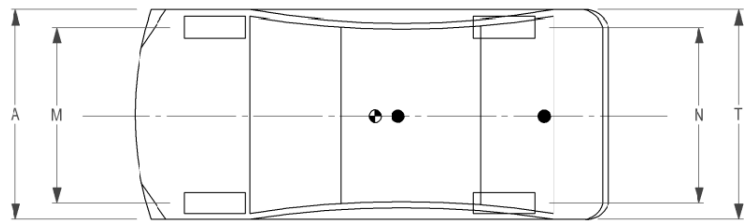
Describe any damage to the vehicle prior to test: None

• Denotes accelerometer location.

NOTES: None  
 \_\_\_\_\_  
 \_\_\_\_\_

Engine Type: 4 cylinder  
 Engine CID: 1.6 L  
 Transmission Type:  
 Auto or  Manual  
 FWD  RWD  4WD  
 Optional Equipment:  
 \_\_\_\_\_  
 \_\_\_\_\_

Dummy Data:  
 Type: 50th percentile male  
 Mass: 165 lb  
 Seat Position: Driver Side



**Geometry:** inches

A	66.38	F	33.00	K	12.25	P	4.12	U	15.75		
B	51.50	G		L	25.25	Q	22.50	V	21.50		
C	165.75	H	35.90	M	57.75	R	15.50	W	35.90		
D	34.00	I	7.75	N	57.70	S	8.25	X	108.00		
E	98.75	J	21.50	O	28.25	T	66.20				
Wheel Center Ht Front		11.00		Wheel Center Ht Rear		11.00		W-H		0.00	

RANGE LIMIT: A = 65 ±3 inches; C = 168 ±8 inches; E = 98 ±5 inches; F = 35 ±4 inches; G = 39 ±4 inches; O = TOP OF RADIATOR SUPPORT (24 ±4 inches); M+N/2 = 56 ±2 inches; W-H < 2 inches or use MASH Paragraph A4.3.2

GVWR Ratings:	Mass: lb	Curb	Test Inertial	Gross Static
Front	1718	M <sub>front</sub>	1560	1645
Back	1874	M <sub>rear</sub>	894	974
Total	3638	M <sub>Total</sub>	2454	2619

Allowable TIM = 2420 lb ±55 lb | Allowable GSM = 2585 lb ± 55 lb

**Mass Distribution:**

lb LF: 781 RF: 779 LR: 423 RR: 471

**Table E.2. Exterior Crush Measurements for Test No. 608331-01-3.**

Date: 2018-12-14 Test No.: 608331-01-3 VIN No.: KNADH4A3XA6680107  
 Year: 2010 Make: Kia Model: Rio

**VEHICLE CRUSH MEASUREMENT SHEET<sup>1</sup>**

Complete When Applicable	
End Damage	Side Damage
Undeformed end width _____ Corner shift: A1 _____ A2 _____ End shift at frame (CDC) (check one) < 4 inches _____ ≥ 4 inches _____	Bowing: B1 _____ X1 _____ B2 _____ X2 _____ Bowing constant $\frac{X1 + X2}{2} = \underline{\hspace{2cm}}$

Note: Measure C<sub>1</sub> to C<sub>6</sub> from Driver to Passenger Side in Front or Rear Impacts – Rear to Front in Side Impacts.

Specific Impact Number	Plane* of C-Measurements	Direct Damage		Field L***	C <sub>1</sub>	C <sub>2</sub>	C <sub>3</sub>	C <sub>4</sub>	C <sub>5</sub>	C <sub>6</sub>	±D
		Width** (CDC)	Max**** Crush								
1	AT FT BUMPER	15	11	30	11	7	5	4	2	1	+11
2	ABOVE FT BUMPER	15	10	44	1	4	6	8	9	10	+60
	Measurements recorded										
	<input checked="" type="checkbox"/> inches or <input type="checkbox"/> mm										

<sup>1</sup>Table taken from National Accident Sampling System (NASS).

\*Identify the plane at which the C-measurements are taken (e.g., at bumper, above bumper, at sill, above sill, at beltline, etc.) or label adjustments (e.g., free space).

Free space value is defined as the distance between the baseline and the original body contour taken at the individual C locations. This may include the following: bumper lead, bumper taper, side protrusion, side taper, etc. Record the value for each C-measurement and maximum crush.

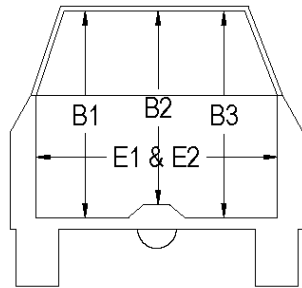
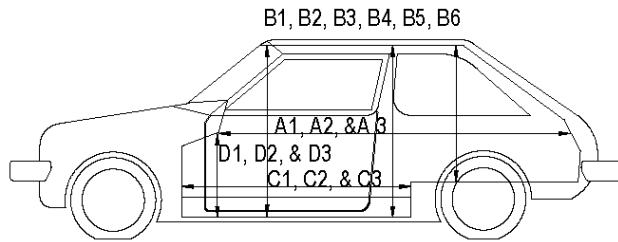
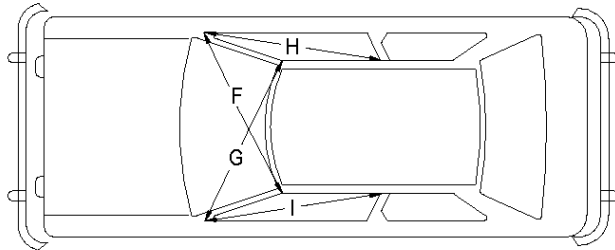
\*\*Measure and document on the vehicle diagram the beginning or end of the direct damage width and field L (e.g., side damage with respect to undamaged axle).

\*\*\*Measure and document on the vehicle diagram the location of the maximum crush.

Note: Use as many lines/columns as necessary to describe each damage profile.

**Table E.3. Occupant Compartment Measurements for Test No. 608331-01-3.**

Date: 2018-12-14 Test No.: 608331-01-3 VIN No.: KNADH4A3XA6680107  
 Year: 2010 Make: Kia Model: Rio

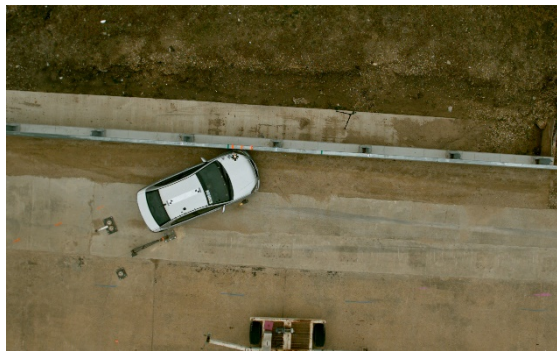


**OCCUPANT COMPARTMENT DEFORMATION MEASUREMENT**

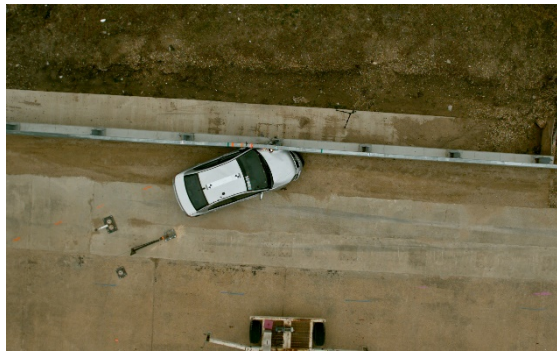
	Before	After (inches)	Differ.
A1	67.50	66.00	-1.50
A2	67.25	67.25	0.00
A3	67.75	67.75	0.00
B1	40.50	39.50	-1.00
B2	39.00	39.00	0.00
B3	40.50	40.50	0.00
B4	36.25	36.25	0.00
B5	36.00	36.00	0.00
B6	36.25	36.25	0.00
C1	26.00	22.00	-4.00
C2	0.00	0.00	0.00
C3	26.00	26.00	0.00
D1	9.50	9.00	-0.50
D2	0.00	0.00	0.00
D3	9.50	9.50	0.00
E1	51.50	53.00	1.50
E2	51.00	52.50	1.50
F	51.00	51.00	0.00
G	51.00	50.50	-0.50
H	37.50	37.25	-0.25
I	37.50	37.50	0.00
J*	51.00	49.50	-1.50

\*Lateral area across the cab from driver's side kick panel to passenger's side kick panel.

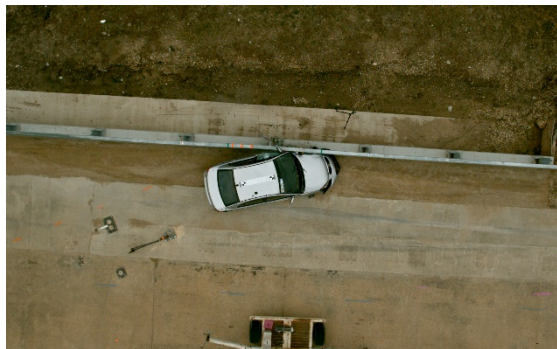
## E2 SEQUENTIAL PHOTOGRAPHS



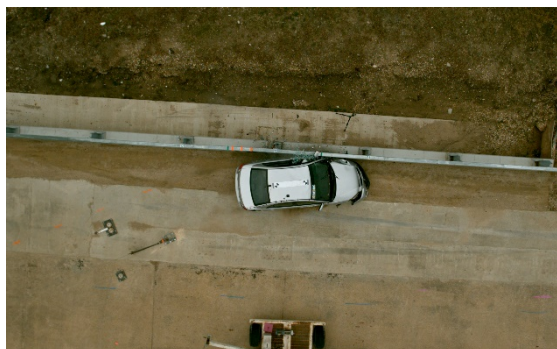
0.000 s



0.050 s



0.100 s

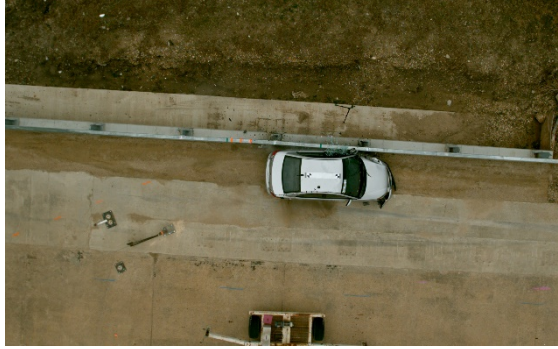


0.150 s



**Figure E.1. Sequential Photographs for Test No. 608331-01-3 (Overhead and Frontal Views).**

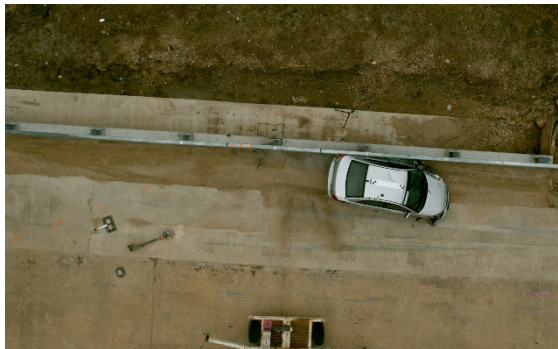




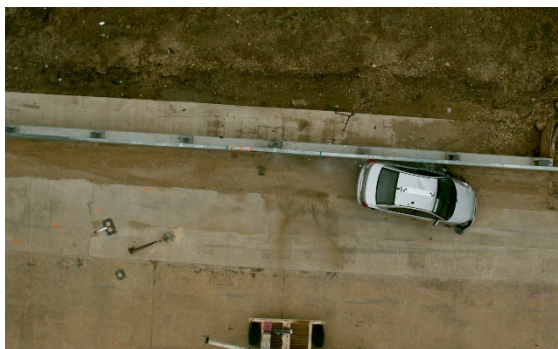
0.200 s



0.250 s



0.300 s



0.350 s



**Figure E.1C.1. Sequential Photographs for Test No. 608331-01-3 (Overhead and Frontal Views) (Continued).**





0.000 s



0.200 s



0.050 s



0.250 s



0.100 s



0.300 s



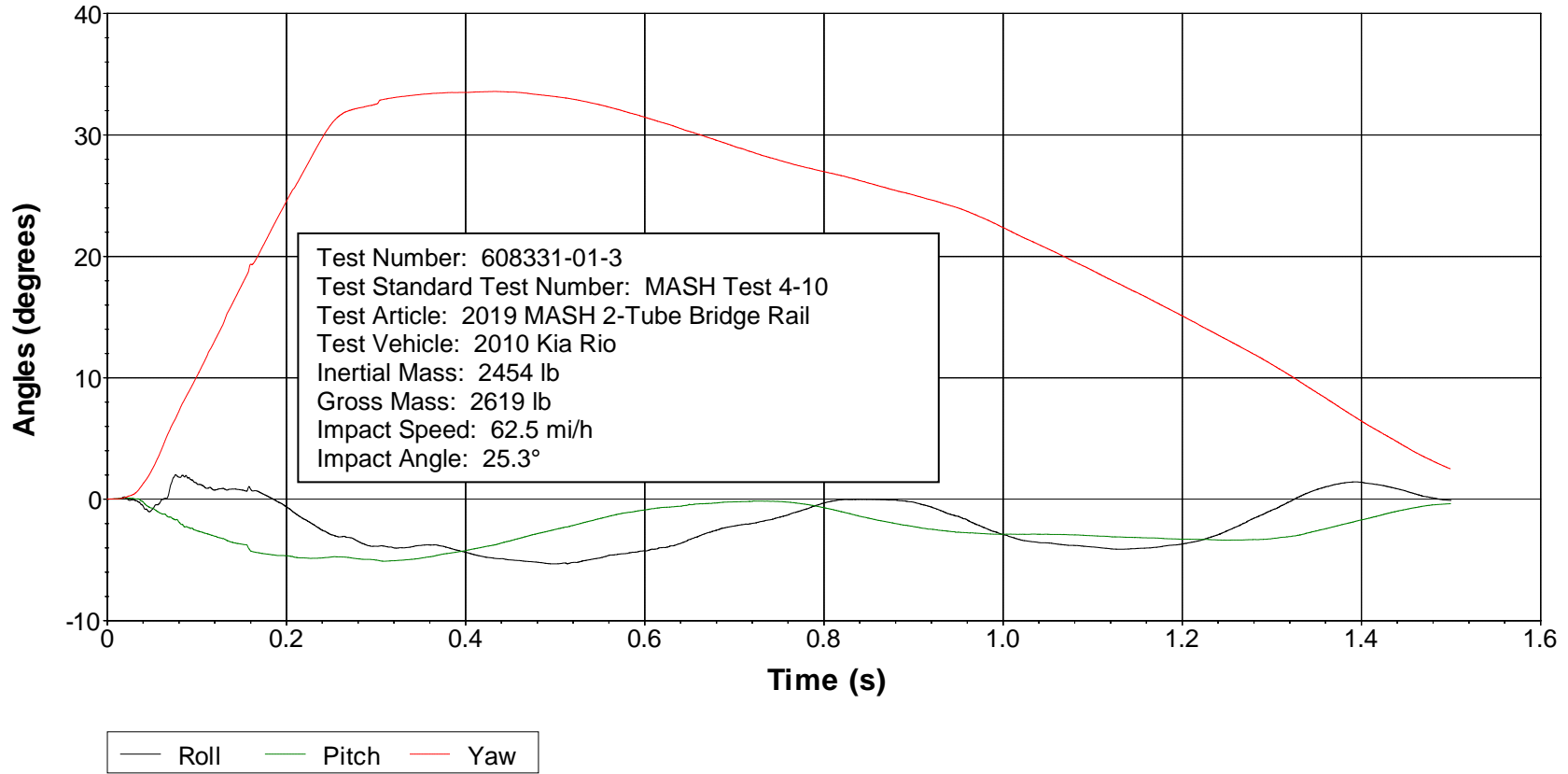
0.150 s



0.350 s

**Figure E.2. Sequential Photographs for Test No. 608331-01-3 (Rear View).**

### Roll, Pitch, and Yaw Angles



Axes are vehicle-fixed.  
 Sequence for determining orientation:

1. Yaw.
2. Pitch.
3. Roll.

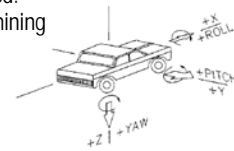
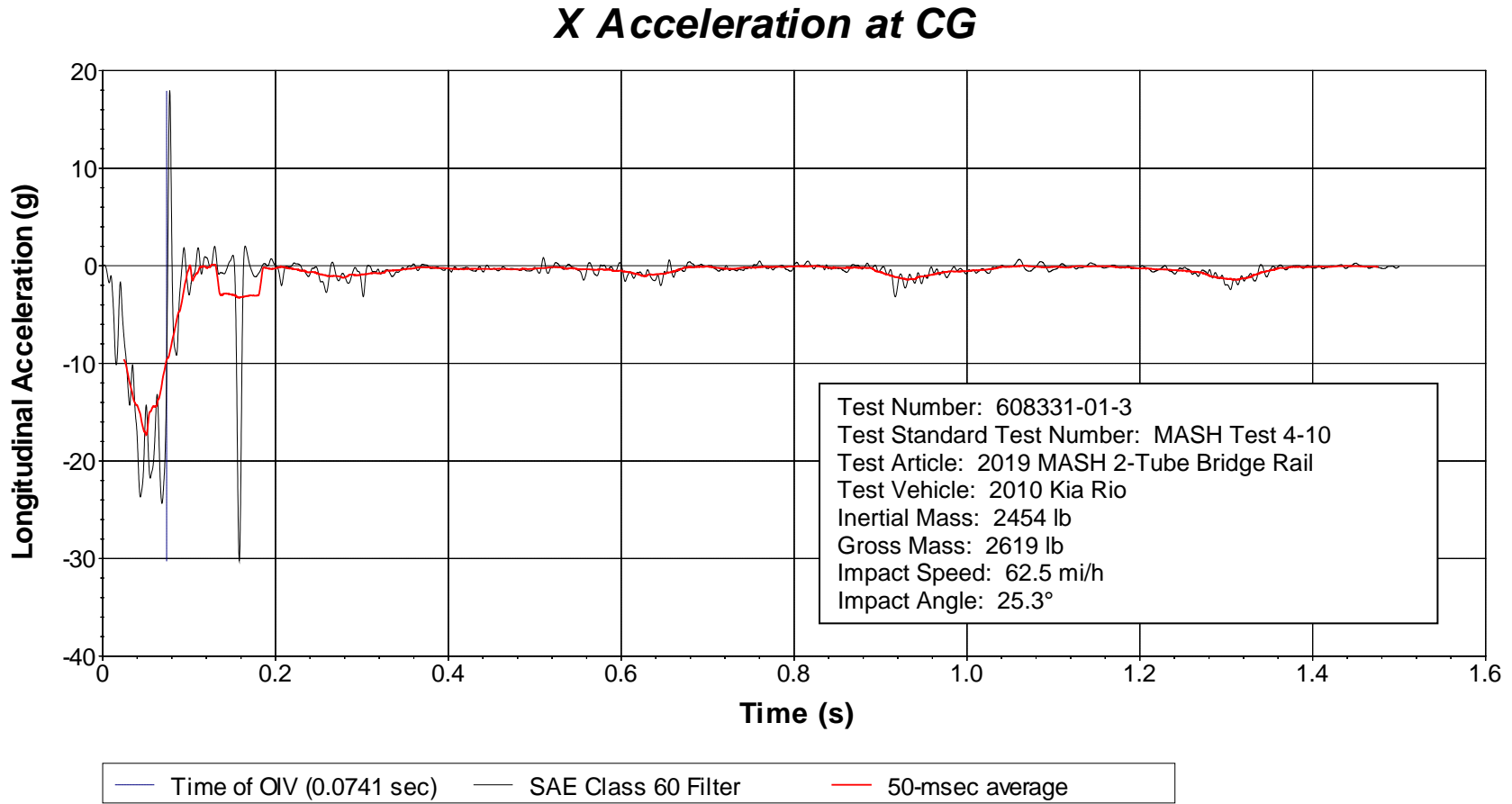


Figure E.3. Vehicle Angular Displacements for Test No. 608331-01-3.



**Figure E.4. Vehicle Longitudinal Accelerometer Trace for Test No. 608331-01-3  
(Accelerometer Located at Center of Gravity).**

### Y Acceleration at CG

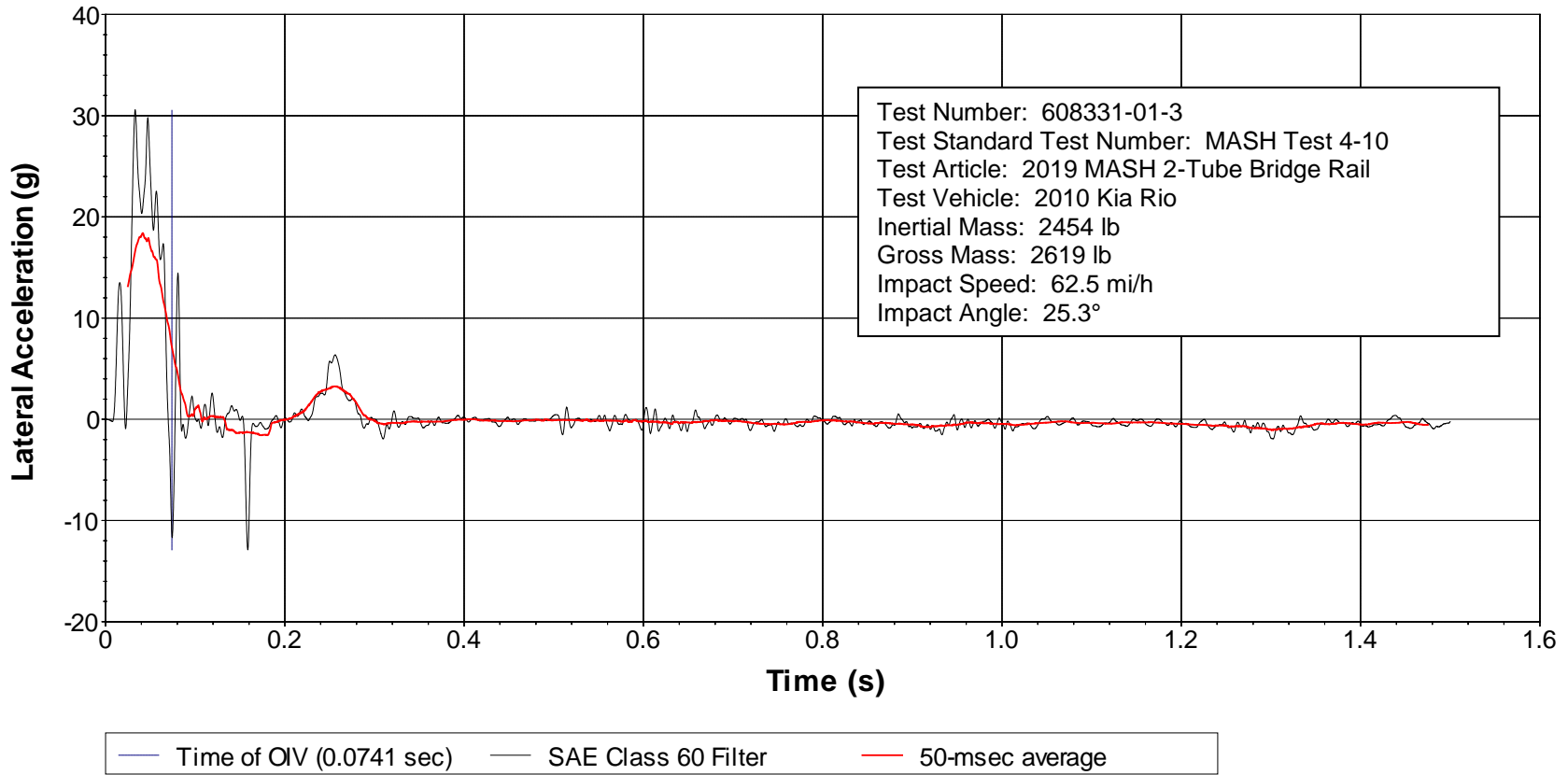


Figure E.5. Vehicle Lateral Accelerometer Trace for Test No. 608331-01-3 (Accelerometer Located at Center of Gravity).

### Z Acceleration at CG

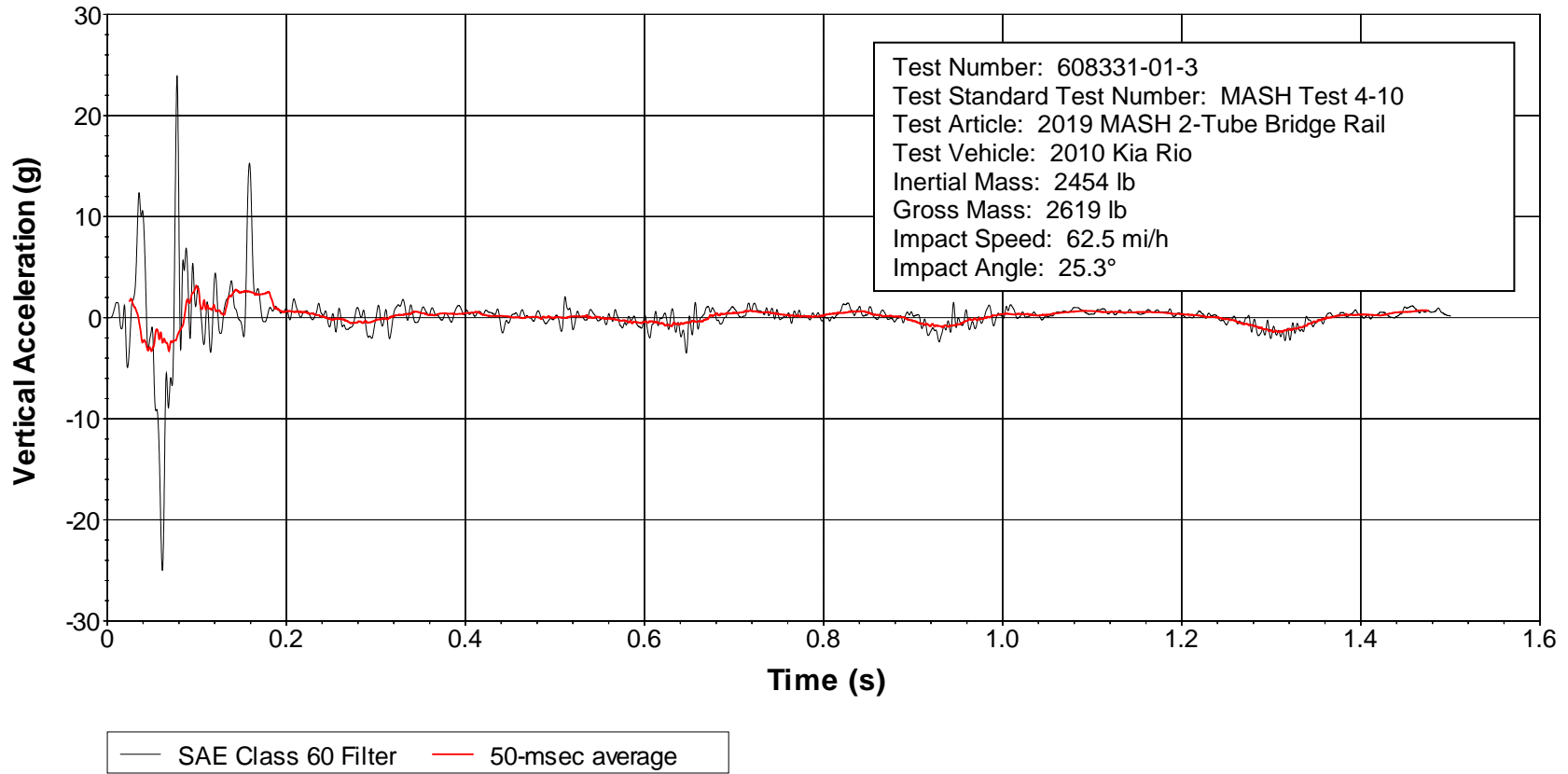
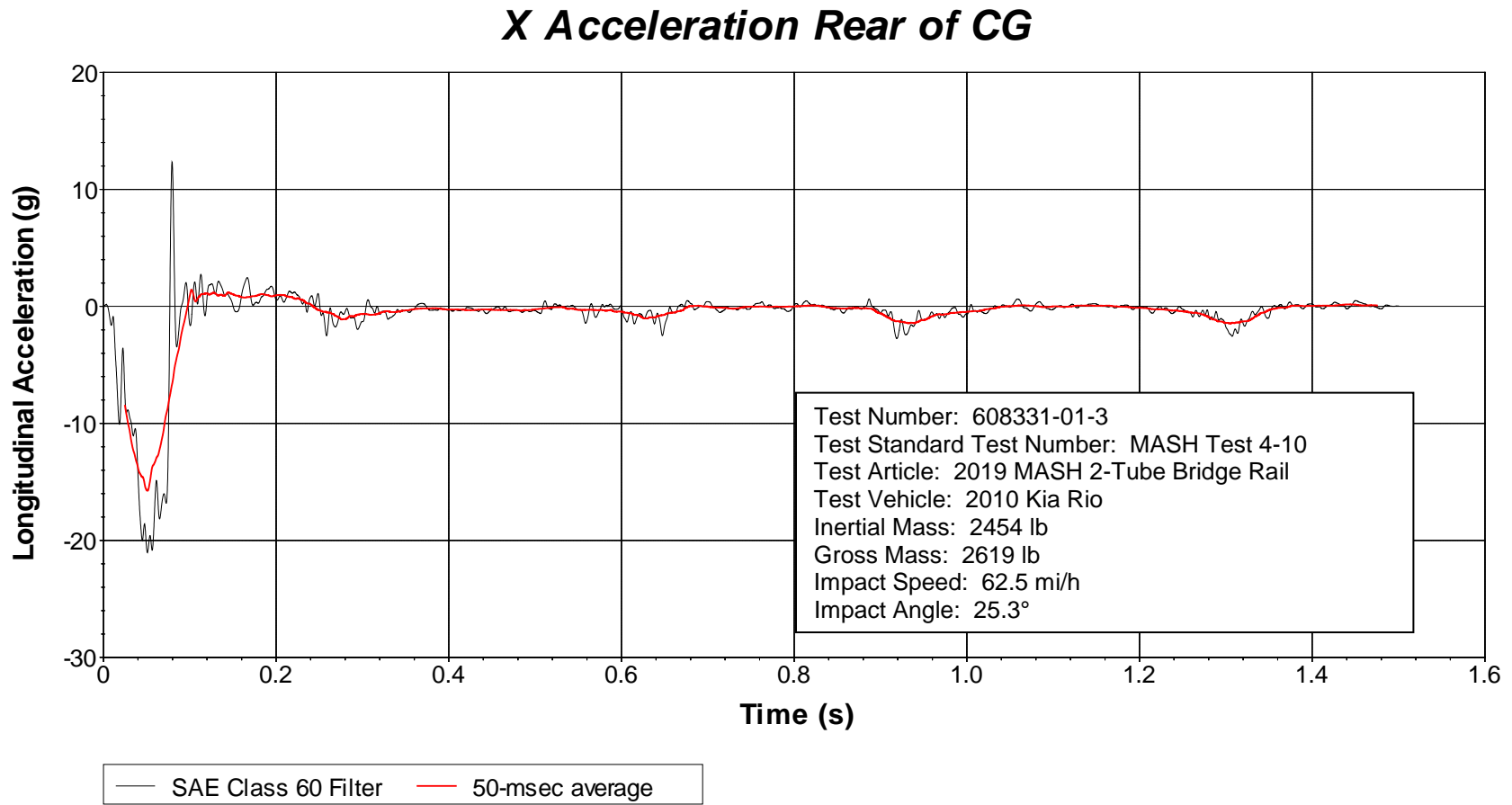
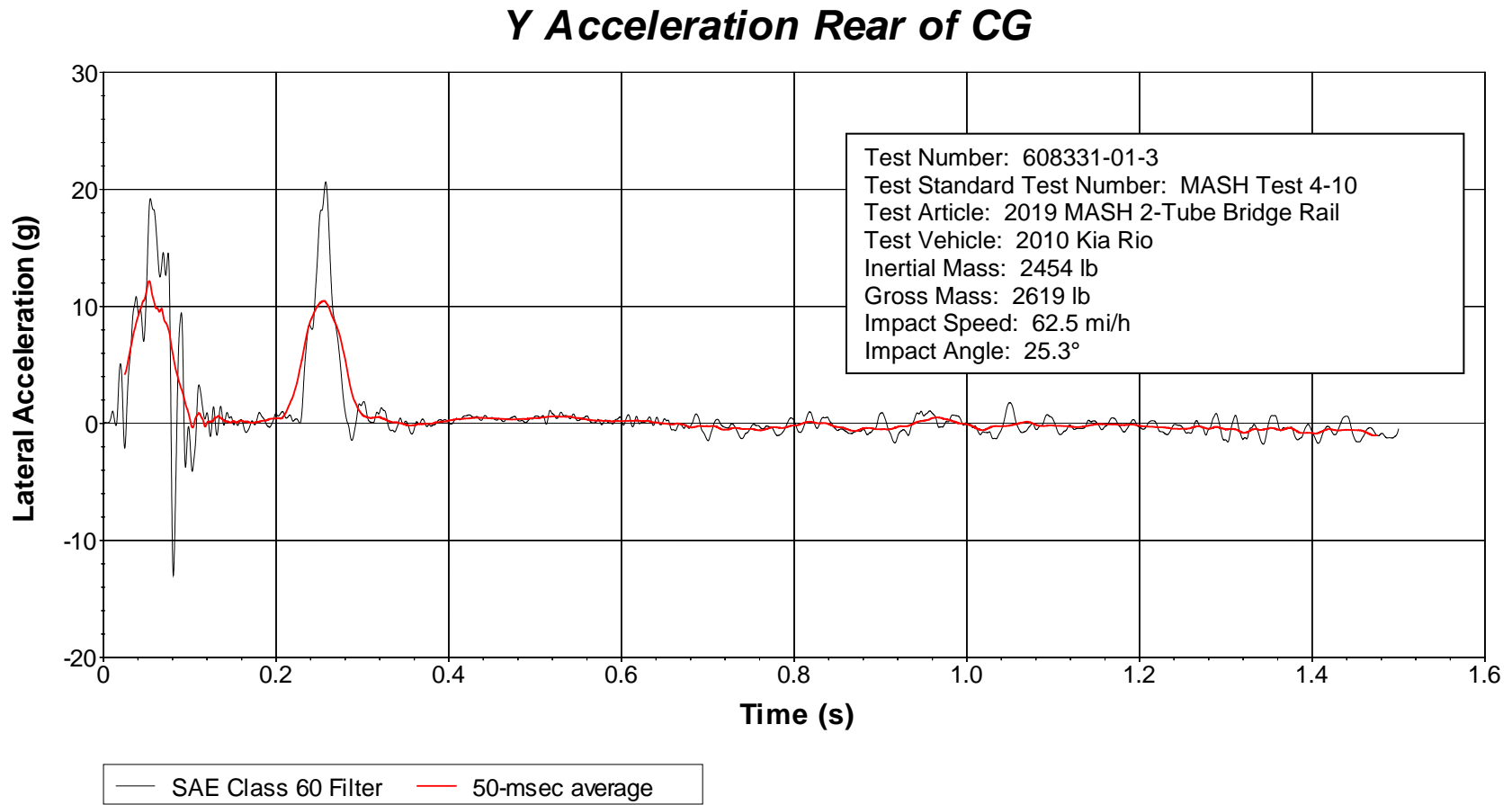


Figure E.6. Vehicle Vertical Accelerometer Trace for Test No. 608331-01-3 (Accelerometer Located at Center of Gravity).

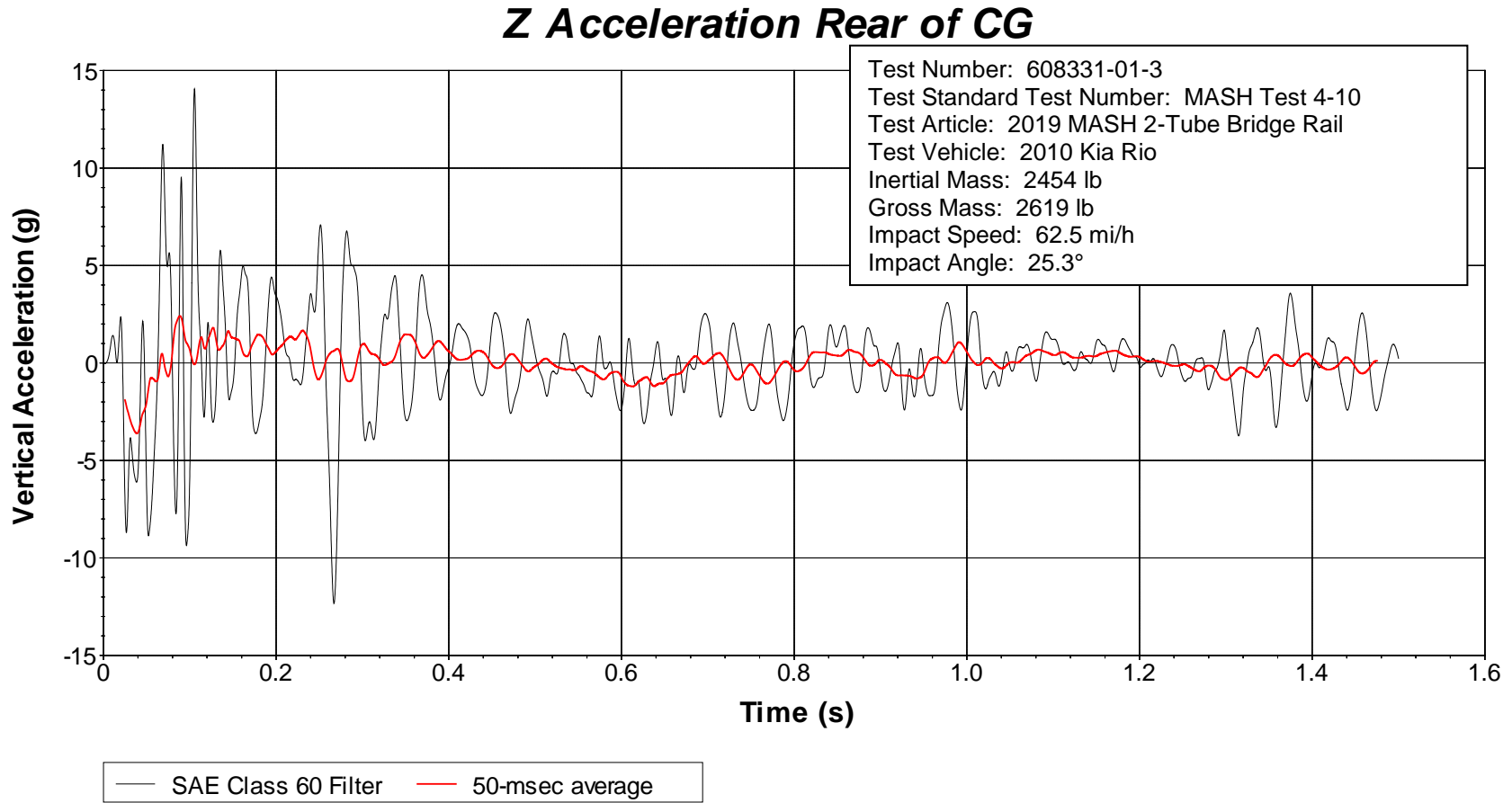




**Figure E.7. Vehicle Longitudinal Accelerometer Trace for Test No. 608331-01-3  
(Accelerometer Located Rear of Center of Gravity).**



**Figure E.8. Vehicle Lateral Accelerometer Trace for Test No. 608331-01-3  
(Accelerometer Located Rear of Center of Gravity).**



**Figure E.9. Vehicle Vertical Accelerometer Trace for Test No. 608331-01-3  
 (Accelerometer Located Rear of Center of Gravity).**